



40in Model 530 Rebounder
with Variable-Bounce Technology
User's Manual

Assembly, Installation, Care, Maintenance, and Use
Instructions

⚠ WARNING

Read these materials prior to assembling and using this Rebounder trampoline



DO NOT attempt or allow somersaults. Landing on the head or neck can cause serious injury, paralysis or death, even when landing in the middle of the bed.



DO NOT allow more than one person on the trampoline. Use by more than one person at the same time can result in serious injury.

Use trampoline only with mature, knowledgeable supervision.

The maximum user weight is 300 pounds. This Rebounder is not recommended for use by children under six years of age.

Retain address information for future use.

JumpSport, Inc.
2055 South 7th Street, Suite A
San Jose, CA 95112 U.S.A.

408-213-2551
www.jumpsport.com

Copyright Notice

This material is protected by United States copyright laws and is proprietary to JumpSport, Inc. Disclosure, reproduction, translation, modification, or use of this document by anyone other than authorized employees, authorized users, or licensees of JumpSport without the prior written consent of JumpSport, Inc. is prohibited.

The information in this document is subject to change without notice. JumpSport, Inc. shall not be liable for any damages resulting from technical errors or omissions, which may be present in this document, or from use of this document.

Copyright © 2003-2006, by JumpSport, Inc. All rights reserved.

Printed: 2006

Version 1.0

Instruction Manual P/N: INS-P-10432B

AlleyOop 40in Model 530 Rebounder with Variable-Bounce Technology, Half-Fold P/N: RBA-S-10428A

AlleyOop 40in Model 530 Rebounder with Variable-Bounce Technology, Quarter-Fold P/N: RBA-S-10429A

Trademarks

JumpSport®, AlleyOop Sports®, and Variable-Bounce™ are trademarks of JumpSport, Inc.

All other brand or product names are trademarks or registered trademarks of their respective companies or organizations.

How to Contact Customer Support

Should you require customer service or technical support for your AlleyOop 40in Model 530 Rebounder with Variable-Bounce Technology, please contact AlleyOop Sports' Customer Service department at:

408-213-2551

8:00am—5:00pm Monday through Friday, Pacific Time



Contents

Chapter 1	Assembly and Installation Instructions	5
	Preparation	5
	Rebounder Placement	5
	Assembly	7
	Unfolding Rebounder	7
	Unfolding Legs	8
	Installing Stabilizer Bar	8
	Folding Rebounder	10
	Adjusting Springs	11
Chapter 2	Care and Maintenance Instructions	12
	Inspection	12
	Replacement Parts	12
	Care	12
Chapter 3	Warning Information	13
	Points of Safety	13
	Bouncing off the Rebounder	13
	Landing Incorrectly on the Mat	13
Chapter 4	Use Instructions	14
	Safety Rules	14
	Warranty Information	Last Page

(This page left intentionally blank.)

Assembly and Installation Instructions

1

Congratulations on purchasing an AlleyOop 40in Model 530 Rebounder with Variable-Bounce Technology! We sincerely believe that you have purchased one of the finest Rebounders on the market. It has been engineered with safety, durability, and performance in mind. This product features our Variable-Bounce mat system.

Preparation

Before you begin using your AlleyOop 40in Model 530 Rebounder with Variable-Bounce Technology, make sure your Rebounder is in a proper location.

Rebounder Placement



Caution: When deciding on where to place your Rebounder, consider the following:

WARNING

- | | |
|---------------------------|--|
| Overhead Clearance | Adequate overhead clearance is essential. A minimum of 24 feet from ground level is recommended for full-size trampolines. Provide clearance for lights, ceiling fans, and other possible hazards. |
| Lateral Clearance | Lateral clearance is essential. Place the Rebounder trampoline away from walls, structures, furniture, and other play areas. Maintain a clear space on all sides of the Rebounder trampoline. |
| Level Surface | Place the Rebounder trampoline on a level surface before use. |
| Lighting | Use the Rebounder trampoline in a well-lit area. Artificial illumination may be required for indoor or shady areas. |
| Security | Secure the Rebounder trampoline against unauthorized and unsupervised use. |
| Ground Clearance | Remove any obstructions from beneath the Rebounder trampoline. |

Note: The owner and supervisors of the Rebounder trampoline are responsible to make all users aware of practices specified in the Use Instructions.

It is the responsibility of the purchaser to become familiar with all of the information in this booklet, to convey the warnings to all users, and to enforce AlleyOop Sports' rules for safe use.

This unit is not intended for commercial or public use and is therefore strictly prohibited.

The maximum user weight is 300 pounds.

This Rebounder trampoline is not recommended for use by children under six years of age.

Assembly and Installation Instructions

Your 530 Rebounder comes with a stabilizer bar (disassembled) and a spring tool (for adjusting the spring tension should you choose to do so). The following pages explain how to unfold your 530 Rebounder, how to unfold the legs, how to install the stabilizer bar, and how to adjust the springs.

Note: For all installation Steps, safety glasses and gloves are recommended for safety.

Before performing any Step, completely read the entire Step first.

If you are missing any pieces, call AlleyOop Sports' Customer Service immediately at 408-213-2551.

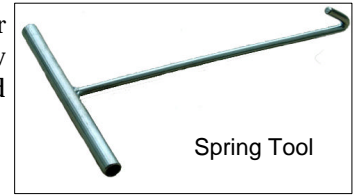

 **WARNING**

Impact Hazard.
Always fold and unfold Rebounder with at least two strong people. Keep head and face away from frame of Rebounder. Failure to do so can cause serious injury to head or face, or lead to other serious injuries.

 **CAUTION**

Pinch Point.
Pay careful attention to hand position when folding and unfolding frame and legs, and when handling springs.

 **CAUTION**

Avoid Injury.
Stabilizer bar (when attached to the Rebounder) is not designed to support your entire weight. It is to aid with balance only.

Assembly and Installation Instructions—Unfolding Rebounder

Unfolding the 530 Half-Fold



WARNING : Always fold and unfold Rebounder with at least two strong people. Keep head and face away from frame of Rebounder. Failure to do so can cause serious injury to head or face, or lead to other serious injuries.

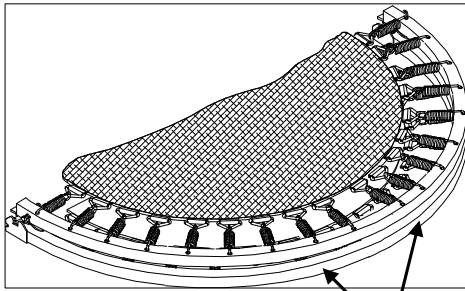

Place feet on lower half of frame for stability.

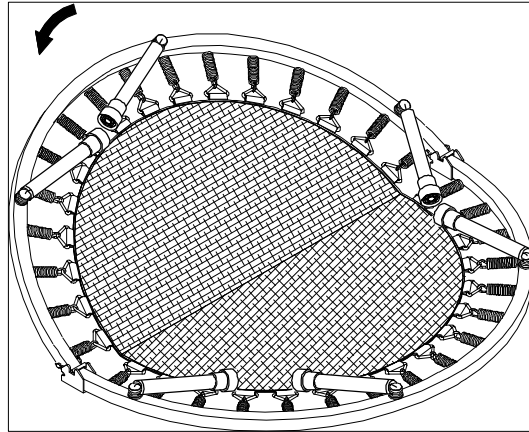

1) To unfold your 530 Half-Fold Rebounder, remove Rebounder from its carry bag and lay Rebounder flat on ground. Open Rebounder by placing your feet on lower half of metal frame, and lift top half up and away from you. Do this slowly, and be sure all springs are connected. If all springs are not connected, reattach them using spring tool provided, before unfolding Rebounder.

Unfolding the 530 Quarter-Fold

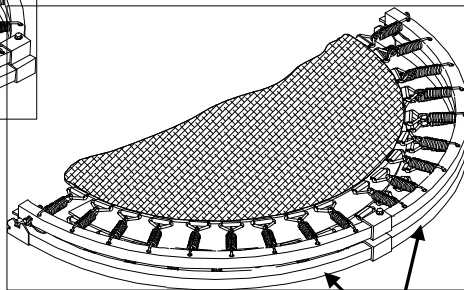
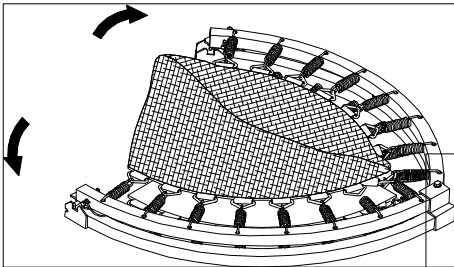

Place feet on lower half of frame for stability.



WARNING : Always fold and unfold Rebounder with at least two strong people. Keep head and face away from frame of Rebounder. Failure to do so can cause serious injury to head or face, or lead to other serious injuries.

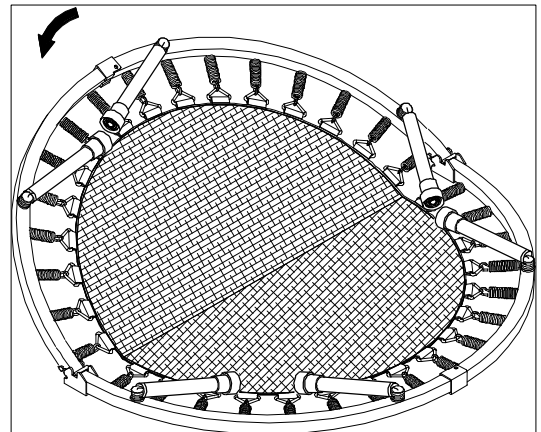

1) To unfold your 530 Quarter-Fold Rebounder, remove Rebounder from its carry bag and lay Rebounder flat on ground. First, push the 2 ends away from each other. Then open Rebounder by placing your feet on lower half of metal frame, and lift top half up and away from you. Do this slowly, and be sure all springs are connected. If all springs are not connected, reattach them using spring tool provided, before unfolding Rebounder.

Assembly and Installation Instructions—Unfolding Legs & Installing Stabilizer Bar

Unfolding the Legs

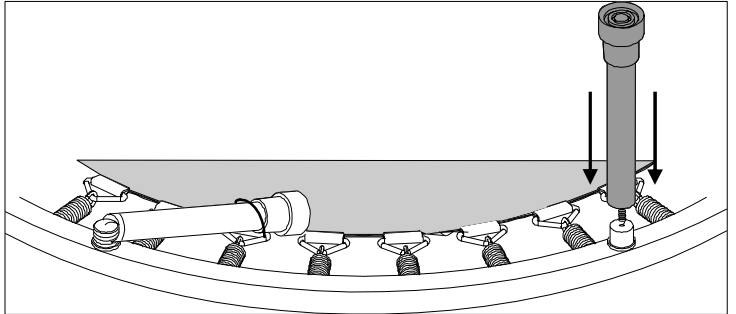
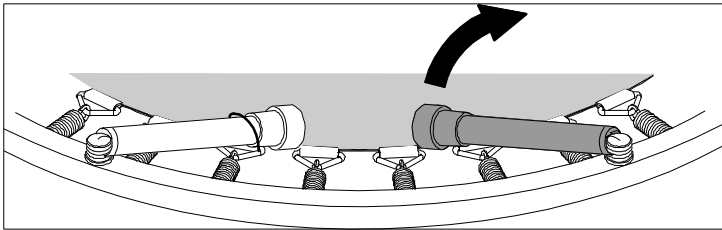

2a) Lay Rebounder upside-down on ground. Remove bungee holding each leg in place, from around each leg. Legs will be attached at one end to a “socket” via a metal spring.

2b) Rotate a leg so that it points straight up into the air. Slowly guide leg down over socket until leg rests against frame. >> Repeat with all remaining legs.

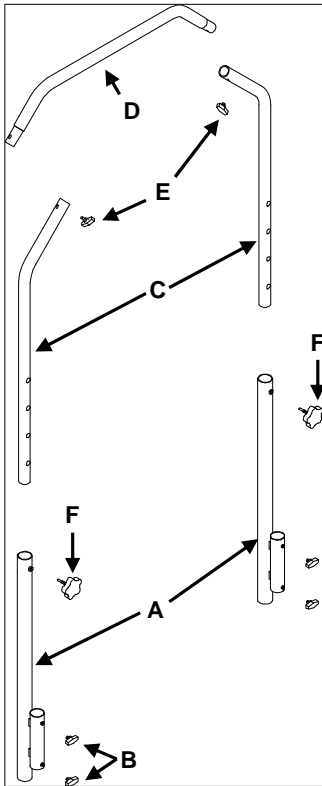

Installing the Stabilizer Bar

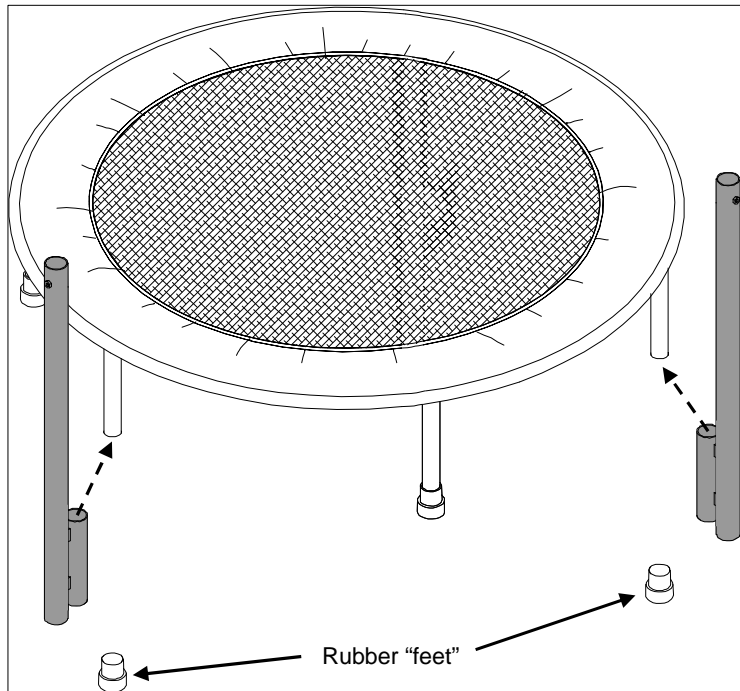

3a) To install stabilizer bar on your 530 Rebounder, first remove rubber “feet” from bottom of 2 legs, as shown. Next place piece A over each leg, then replace rubber feet.

Assembly and Installation Instructions—Installing Stabilizer Bar

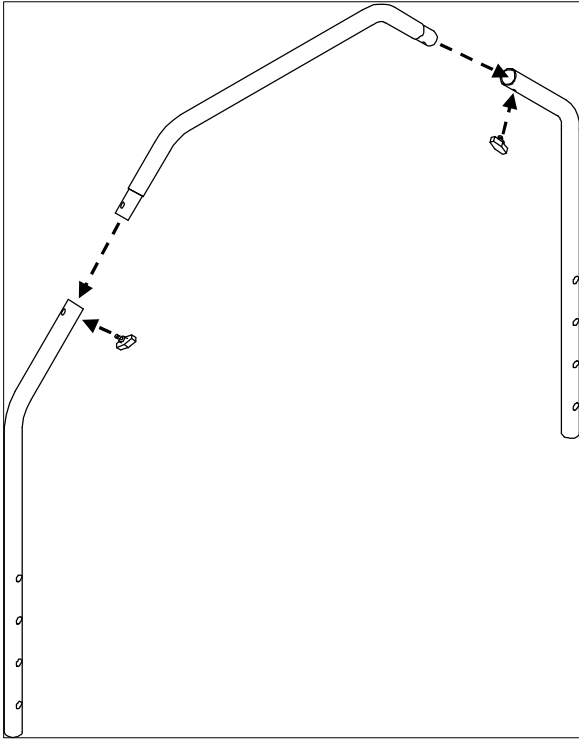

3b) Now connect piece D to top of both C pieces. Use piece E to secure pieces C and D together. You now have a “top assembly”.

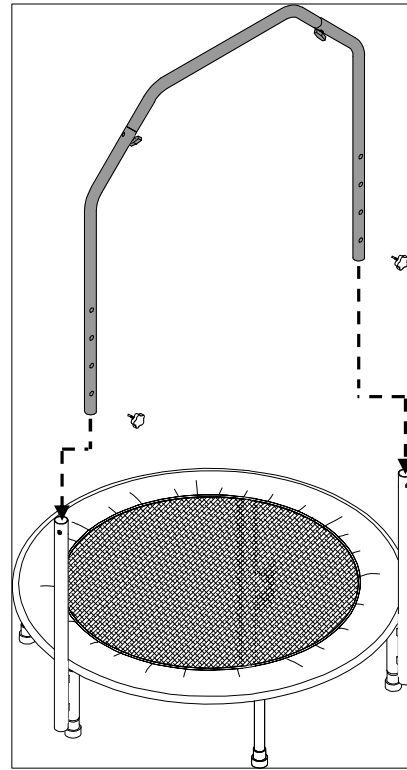

3c) Lower top assembly into both A pieces until bottom hole in top assembly lines up with hole at top of each A piece. You may have to rotate each A piece for top assembly to fit. Secure top assembly in place with F pieces.

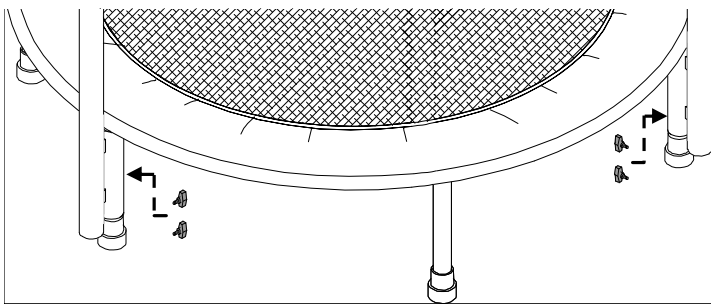

3d) Secure B pieces to bottom of both A pieces.

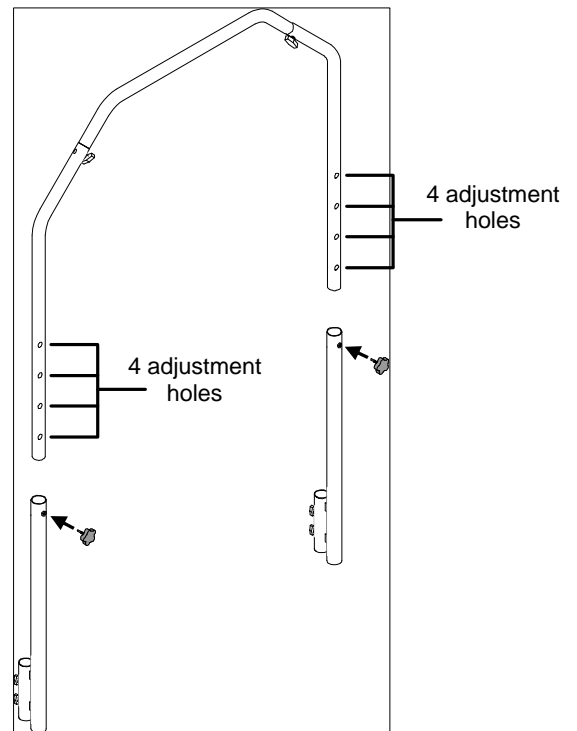

3e) To change height of stabilizer bar, remove F pieces, move top assembly to desired height, then screw F pieces back in place. There are 4 different height adjustments for the stabilizer bar.

Assembly and Installation Instructions—Folding Rebounder



WARNING : Always fold and unfold Rebounder with at least two strong people. Keep head and face away from frame of Rebounder. Failure to do so can cause serious injury to head or face, or lead to other serious injuries.

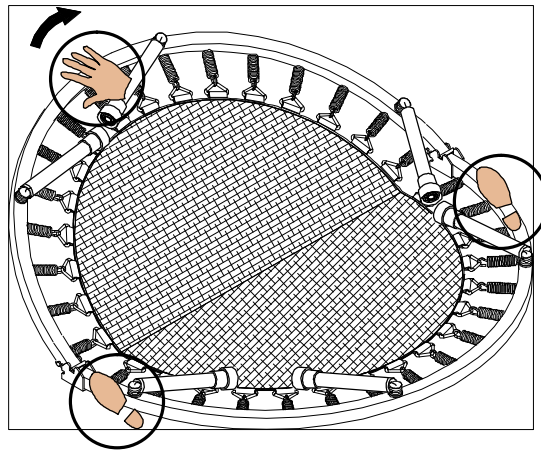

4) To fold and store your Rebounder:

- First remove stabilizer bar, following instructions for stabilizer bar installation in reverse order.
- Then fold legs of Rebounder, following instructions for unfolding them in reverse order (be sure to secure legs to Rebounder with bungees).
- Last, turn Rebounder upside-down. Place feet on outer edge (frame) of Rebounder as shown. Firmly grasp far side of frame, as shown. Slowly lift far side of Rebounder toward you. Fold Half-fold or Quarter-fold together, following instructions for unfolding Rebounder in reverse order.

Assembly and Installation Instructions—Adjusting Springs

Adjusting the Spring Tension for a Firmer Feel

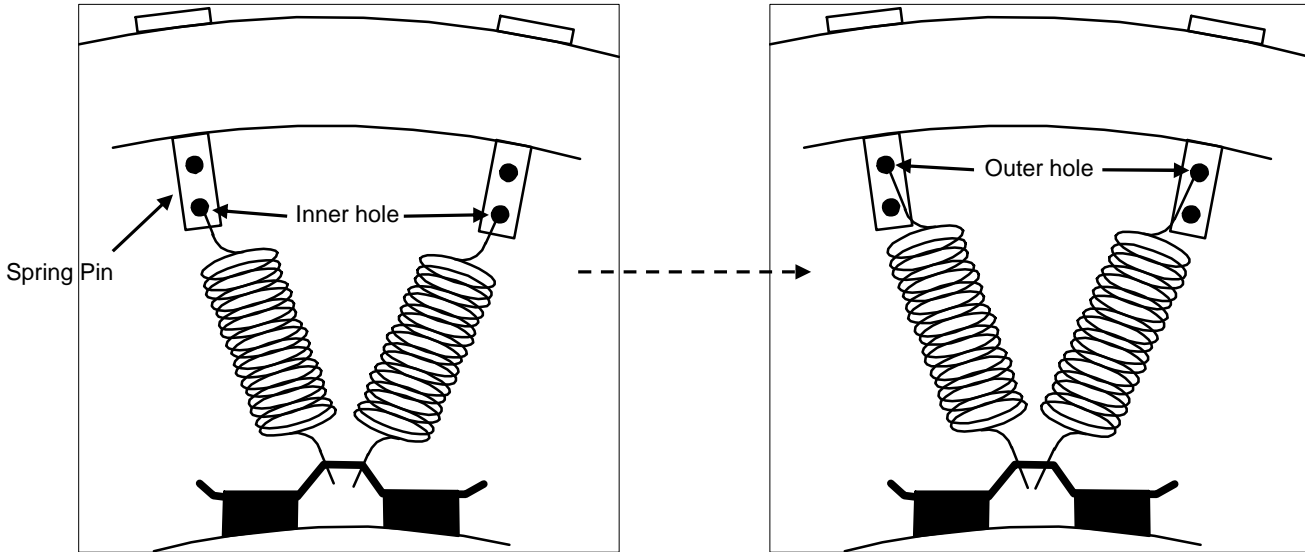

5) If jumping surface (mat) feels too *soft*, fold Rebounder closed (see previous page for instructions). While Rebounder is folded, unhook each spring from mat using spring tool, then from each spring pin. Then reconnect each spring to *outer* hole of spring pin. Next reconnect each spring to the mat using spring tool. Now you are ready to unfold Rebounder again and begin use.

Adjusting the Spring Tension for a Softer Feel

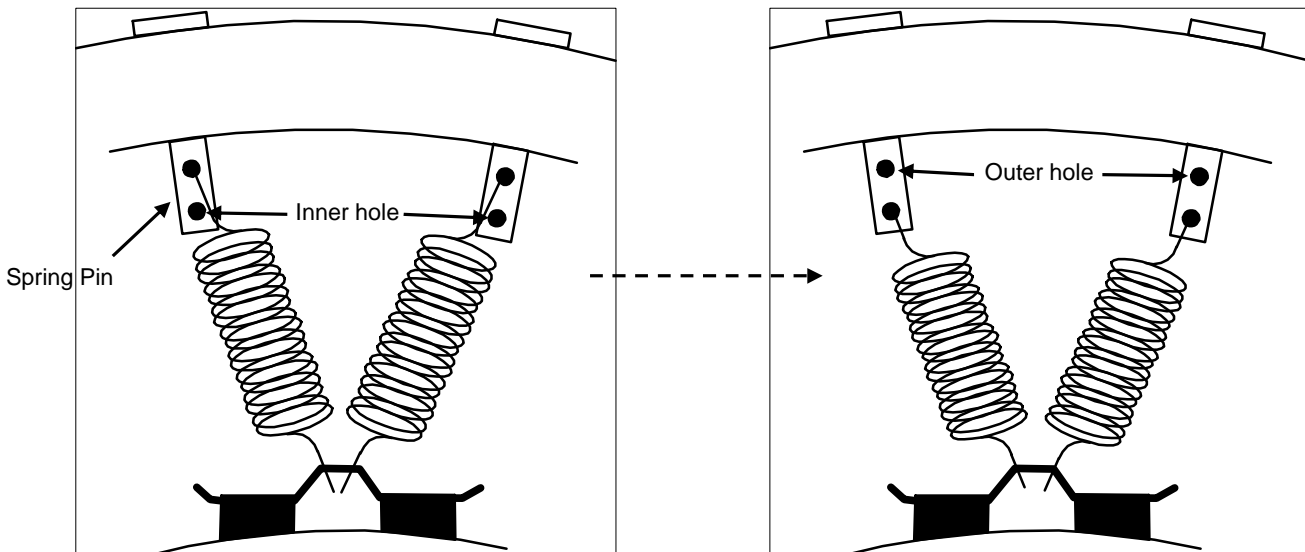

5) If jumping surface (mat) feels too *firm*, fold Rebounder closed (see previous page for instructions). While Rebounder is folded, unhook each spring from mat using spring tool, then from each spring pin. Then reconnect each spring to *inner* hole of spring pin. Next reconnect each spring to the mat using spring tool. Now you are ready to unfold Rebounder again and begin use.

Care and Maintenance Instructions

2

Your AlleyOop 40in Model 530 Rebounder with Variable-Bounce Technology is made using quality materials and is finely-crafted to provide you with many years of enjoyment and exercise. Proper maintenance and care will help to prolong the life of the Rebounder trampoline and reduce the possibility of injury.

All Rebounder trampolines require maintenance at some point. The following maintenance guidelines should always be observed.

Inspection

Inspect the Rebounder trampoline before each use and replace any worn, defective, or missing parts. The following conditions could represent potential hazards:

- Missing, improperly positioned, or insecurely attached frame padding
- Puncture, frays, tears, or holes worn in the bed or frame padding
- Deterioration in the stitching or fabric of the bed or frame padding
- Ruptured springs
- A bent or broken frame
- A sagging bed
- Sharp protrusions on the frame or suspension system

Note: The "bed" mentioned above and elsewhere in this manual, refers to the jumping surface (generally referred to as the "mat").

If any of the above conditions exist, your Model 530 Rebounder must be protected against use until the condition is remedied.

Replacement Parts

All replacement parts should be ordered through AlleyOop Sports. Stores that repair shoes, awnings, or tents, as well as upholstery shops, do not have the proper materials, equipment, or methods for the proper/safe repair of Rebounder trampoline mats and frame pads.

Call **AlleyOop Sports** at 408-213-2551 if you need replacement parts, or have any questions.

If any warning labels or signs become unreadable or missing, call AlleyOop Sports for free replacements.

Rebounder trampoline mats should be completely replaced if any tear or hole is greater than one inch in length. Patches over larger holes will eventually fail, creating a potential for hazardous injury.



Caution: Do not repair Rebounder trampoline mats with holes greater than one inch.

Care

Do not allow family pets on the Rebounder trampoline, as claws may snag and pull the trampoline mat material or damage the frame pad.

The Model 530 Rebounder Trampoline is intended to be used by one person at a time, weighing less than 300 pounds. The user should either be barefoot or wearing gymnastic slippers or non-cleated athletic shoes. The user should remove all sharp objects from their person that may cause injury or damage to the trampoline mat. Heavy, sharp, or hard pointed objects should not contact the mat surface.

WARNING



DO NOT attempt or allow somersaults. Landing on the head or neck can cause serious injury, paralysis or death, even when landing in the middle of the bed.



DO NOT allow more than one person on the trampoline. Use by more than one person at the same time can result in serious injury.

Use trampoline only with mature, knowledgeable supervision.

Points of Safety

It is essential that Rebounder trampoline users follow a carefully planned safety program so that the trampoline can be fully enjoyed. Most accidents can be classified into the following:

- Bouncing off the Rebounder trampoline
- Landing incorrectly on the mat

These are covered in detail in the following sections.

Bouncing off the Rebounder Trampoline

Bouncing off of the Rebounder trampoline can be controlled, if not completely eliminated, through:

- Strictly forbidding any “flying dismounts” (i.e. jumping off of the trampoline onto another object or the ground)
- Using the trampoline only with mature, knowledgeable supervision

Keep objects away from the Rebounder trampoline. It is dangerous to jump from the trampoline to the floor or ground. Do not jump from the trampoline onto a piece of furniture or any other object.

Landing Incorrectly on the Mat

Landing incorrectly on the mat creates great risk of a serious injury, with most injuries resulting from attempted somersaults/flips. It is strongly recommended that somersaults/flips are not performed.

Safety Rules

It is the responsibility of the owner to become familiar with the safety rules and to convey these rules to all users.

WARNING

- **Always fold and unfold Rebounder with at least two strong people. Keep head and face away from frame of Rebounder. Failure to do so can cause serious injury to head or face, or lead to other serious injuries.**
- You should consult with a physician before beginning any exercise or conditioning program.
- If you feel faint or dizzy, immediately stop using the Rebounder trampoline.
- DO NOT attempt or allow somersaults. Landing on your head or neck can cause serious injury, paralysis, or death, even when landing in the middle of the bed.
- DO NOT allow more than one person on the trampoline. Use by more than one person at the same time can result in serious injuries.
- Use trampoline only with mature, knowledgeable supervision.
- Rebounder trampolines are not recommended for use by children under 6 years of age.
- Inspect the trampoline before each use. Make sure the frame padding is correctly and securely positioned. Replace any worn, defective, or missing parts.
- Climb on and off the trampoline. It is a dangerous practice to jump from the trampoline to the floor or ground when dismounting, or to jump onto the trampoline when mounting. Do not use the trampoline as a springboard to other objects.
- Stop bounce by flexing knees as feet come in contact with the trampoline bed. Learn this skill before attempting others.
- Learn fundamental bounces and body positions thoroughly before trying more advanced skills. A variety of trampoline activities can be carried out by performing the basic fundamentals in various series and combinations, performing one fundamental after another, with or without feet bounces between them.
- Avoid bouncing too high. Stay low until bounce control and repeated landing in the center of the trampoline can be accomplished. Control is more important than height.
- While keeping the head erect, focus eyes on the trampoline toward the perimeter. This will help control bounce.
- Avoid bouncing when tired. Keep turns short.
- Properly secure the trampoline when not in use. Protect it against unauthorized use.
- Keep objects away which could interfere with the performer. Maintain a clear area around the trampoline.
- Do not use the trampoline while under the influence of alcohol or drugs.
- For additional information concerning the trampoline equipment, contact the manufacturer.
- For information concerning skill training, contact a certified trampoline instructor.
- Bounce only when the surface of the bed is dry. Wind or air movement should be calm to gentle. The trampoline must not be used in gusty or severe winds.
- Read all instructions before using the trampoline. Warnings and instructions for the care, maintenance, and use of this trampoline are included to promote safe, enjoyable use of this equipment.

Note: *The "bed" mentioned above and elsewhere in this manual, refers to the jumping surface (generally referred to as the "mat").*

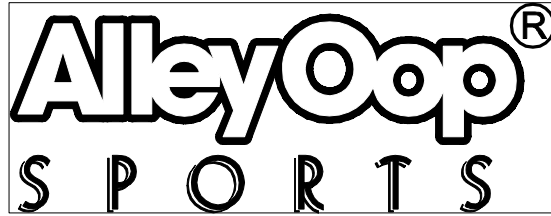

Limited Lifetime Warranty

What is covered by this warranty? This warranty covers any defects in materials or workmanship on all of the components of the AlleyOop 40in Model 530 Rebounder with Variable-Bounce Technology. The warranty also covers a one-time replacement for each individual component of the trampoline, should a failure occur as a result of normal wear and tear. The warranty is extended exclusively to the original retail purchaser.

How long does this coverage last? Warranty coverage for defects and one-time replacements begins from the original date of purchase and lasts for as long as you own the product.

What will AlleyOop Sports do? If you return the defective part to AlleyOop Sports, as instructed below, AlleyOop Sports will either repair or replace such part, at AlleyOop Sports' discretion, and return it to you.

What is not covered by this warranty? This warranty does not cover expenses of on-site labor, travel, assembly or disassembly, or other charges associated with the repair or replacement of covered components. This warranty also does not cover any problem that is caused by abuse, misuse, commercial or public use, ordinary wear and tear (beyond the one-time replacement as described above), weathering, acts of God (such as wind and lightning), failure to follow directions, improper installation, or improper maintenance. Rust is a natural occurrence with any steel product and is likewise not covered by this warranty, to the extent that it does not affect the structural integrity of the part.

ALLEYOOP SPORTS IS NOT RESPONSIBLE OR LIABLE FOR INDIRECT, SPECIAL, OR CONSEQUENTIAL DAMAGES ARISING OUT OF OR IN CONNECTION WITH THE USE OR PERFORMANCE OF THE PRODUCT OR OTHER DAMAGES WITH RESPECT TO ANY LOSS, INCLUDING BUT NOT LIMITED TO ECONOMIC LOSS, LOSS OF PROPERTY, LOSS OF REVENUE OR PROFITS, LOSS OF ENJOYMENT OR USE, COST OF REMOVAL, INSTALLATION OR OTHER CONSEQUENTIAL DAMAGES. SOME STATES DO NOT ALLOW THE EXCLUSION OR LIMITATION OF INCIDENTAL OR CONSEQUENTIAL DAMAGES. ACCORDINGLY, THE ABOVE LIMITATION MAY NOT APPLY TO YOU.

THE WARRANTY EXTENDED HEREUNDER IS IN LIEU OF ALL OTHER WARRANTIES AND ANY IMPLIED WARRANTY OF MERCHANTABILITY OR FITNESS FOR A PARTICULAR PURPOSE IS LIMITED IN ITS SCOPE AND DURATION TO THE TERMS SET FORTH HEREIN. SOME STATES DO NOT ALLOW LIMITATIONS ON HOW LONG AN IMPLIED WARRANTY LASTS. ACCORDINGLY, THE ABOVE LIMITATION MAY NOT APPLY TO YOU.

How to get a defective part replaced:

- 1) Call the AlleyOop Sports Customer Service department at 408-213-2551 to obtain a Return Authorization number. All returns must be pre-authorized.
- 2) Send the part(s) to the designated Service Center, along with a copy of your original sales receipt and a brief written description of the problem, including how it occurred. You must pay freight and insurance to return the part to AlleyOop Sports. At AlleyOop Sports' sole discretion, we may ask you to send photographs in addition to or in lieu of returning the part.
- 3) After inspecting the returned part(s), AlleyOop Sports will make a final determination whether the part is covered by this warranty. We reserve the right to examine photographs or physical evidence concerning parts claimed to be defective prior to making a final determination concerning the claim. A repaired or replacement part will be returned to you. Please allow 3 to 4 weeks for delivery.

This warranty gives you specific legal rights. You may also have other rights which vary from state to state.

JumpSport, Inc.
2055 South 7th Street, Suite A
San Jose, CA 95112

408-213-2551

<http://www.jumpsport.com>