

14ft Deluxe Universal Frame Pad Installation Instructions

Retain address information for future use.

JumpSport, Inc.
2055 South 7th Street, Suite A
San Jose, CA 95112 U.S.A.

408-213-2551
www.jumpsport.com

Copyright Notice

This material is protected by United States copyright laws and is proprietary to JumpSport, Inc. Disclosure, reproduction, translation, modification, or use of this document by anyone other than authorized employees, authorized users, or licensees of JumpSport without the prior written consent of JumpSport, Inc. is prohibited.

The information in this document is subject to change without notice. JumpSport, Inc. shall not be liable for any damages resulting from technical errors or omissions, which may be present in this document, or from use of this document.

Copyright © 2003-2006, by JumpSport, Inc. All rights reserved.

Printed: 2006

Instruction Manual P/N: INS-P-10487B

AlleyOop 14ft Deluxe Universal Frame Pad P/N: PAD-S-10426A

Trademarks

JumpSport® and AlleyOop Sports® are trademarks of JumpSport, Inc.

All other brand or product names are trademarks or registered trademarks of their respective companies or organizations.

How to Contact Customer Support

Should you require customer service or technical support for your AlleyOop 14ft Deluxe Universal Frame Pad, please contact AlleyOop Sports' Customer Service department at:

408-213-2551

8:00am—5:00pm Monday through Friday, Pacific Time



Assembly and Installation Instructions

Thank you for purchasing an AlleyOop 14ft Deluxe Universal Frame Pad!

The following pages contain diagrams, pictures, and written instructions for installing your 14ft Deluxe Universal Frame Pad.

Before performing any Step, completely read the entire Step first.



Trampoline use is not recommended without the frame pad installed (see Picture A, below). The frame pad is designed to reduce the possibility of injury by protecting the user from coming into contact with the frame and springs of the trampoline. It is very important that you properly and securely attach the frame pad to the frame, and that it is in the correct position prior to using the trampoline.



Frame Pad Placement - Showing Correct Placement over Frame Rails and Springs
(Section of frame pad removed for clarity. Be sure pad is completely installed before use.)

Parts List

Your 14ft Deluxe Universal Frame Pad comes with a 1 piece frame pad and 8 pad bungees.

Assembly and Installation Instructions

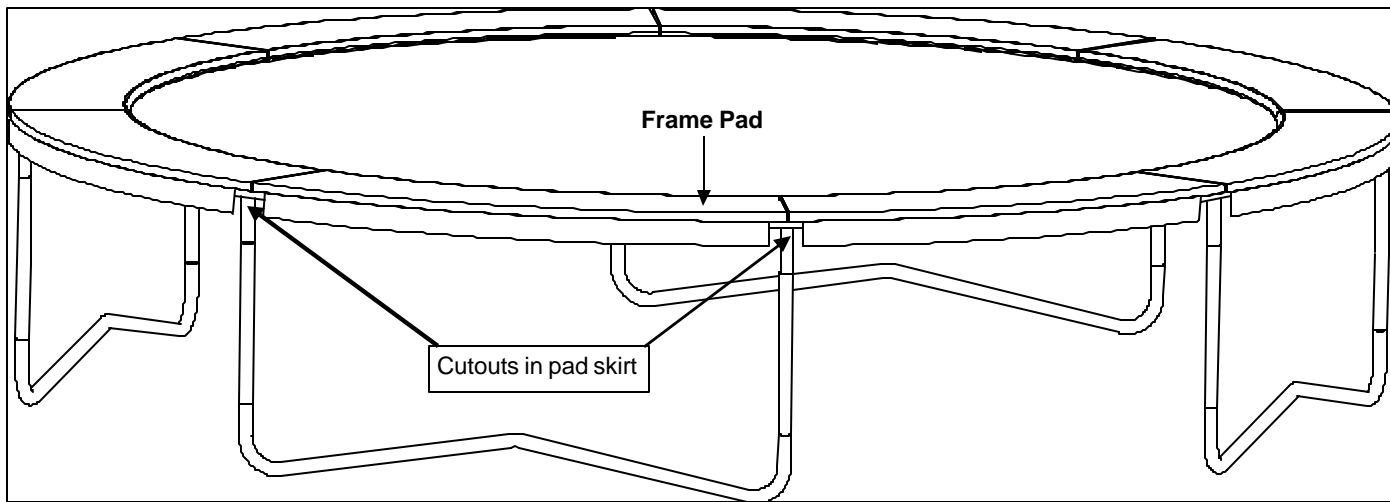

1) Lay frame pad on trampoline. Align pad so that cutouts on outside edge of pad skirt line up over each leg of trampoline. If they do not line up, rotate pad to an adjacent leg.



2) Install pad bungees through the 2 grommets near edge of pad, as shown. Grommets should be on bottom side of pad.

If your safety enclosure poles attach to the outside of your trampoline legs, continue to Step 3. If your safety enclosure poles attach to the inside of your trampoline frame, skip to Step 4.

Assembly and Installation Instructions

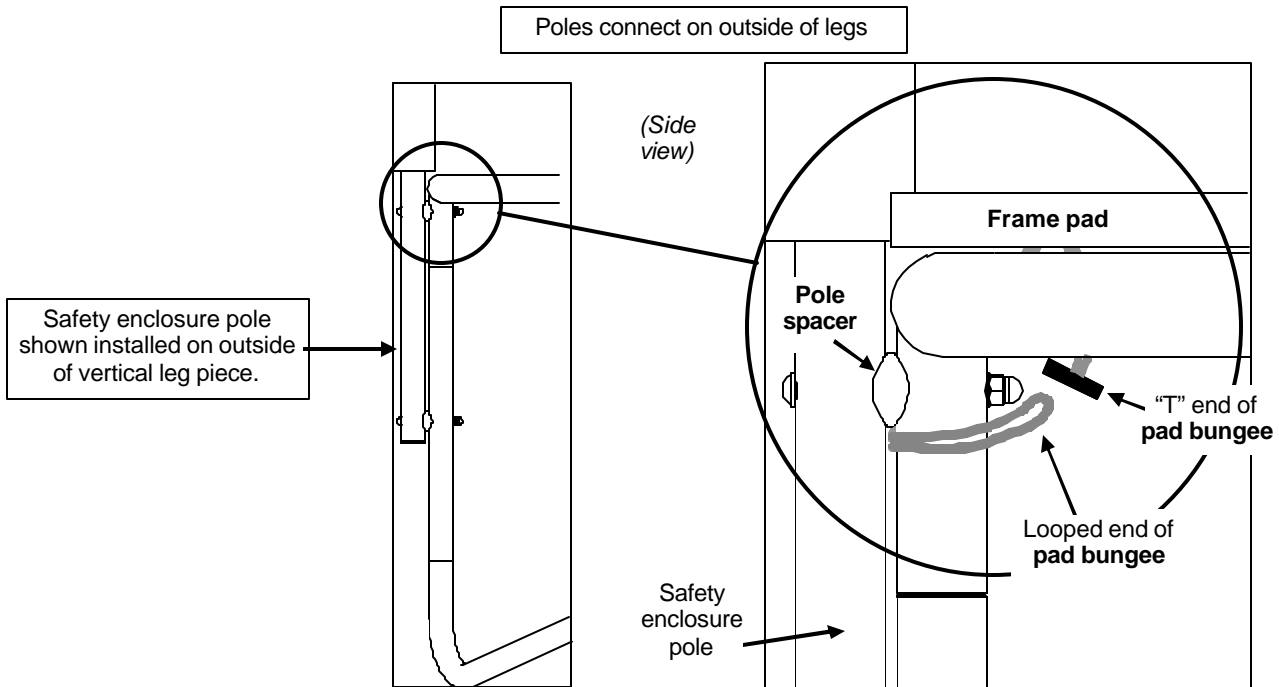

3) If you have a safety enclosure with poles installed on the *outside* of the vertical leg pieces, wrap pad bungees between the vertical leg piece and pole, just below top pole spacer, as shown. If you do not have pole spacers, then wrap pad bungee around both the pole and leg. Then wrap looped end of pad bungee around the "T" on the opposite end of bungee.

Note: Be sure pad bungee can move freely after connecting around leg of trampoline.

When completed, skip to Step 5.

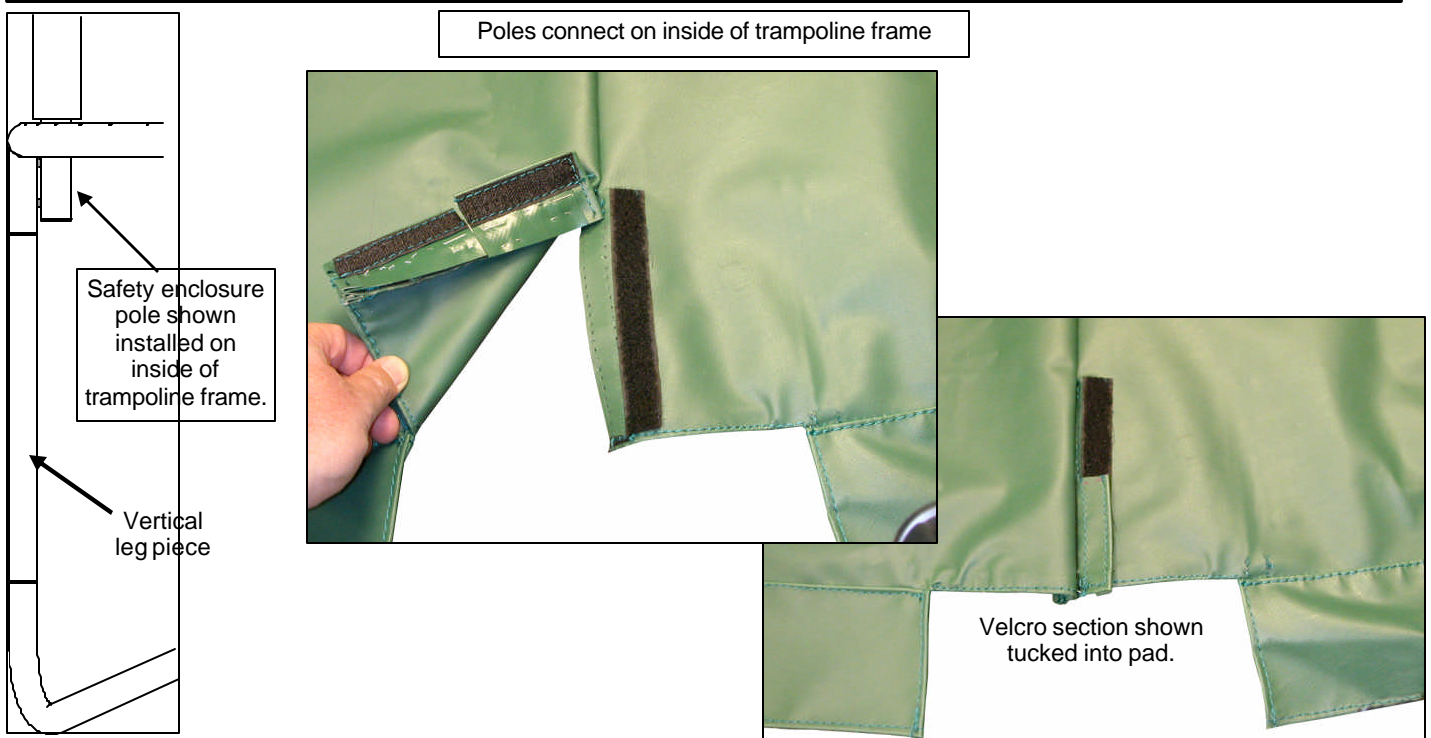

4) If you have a safety enclosure with poles installed on the *inside* of the trampoline frame, wrap pad around the pole using Velcro sections as shown. Depending on where your pole is located, tuck appropriate Velcro flap down to the inside of pad as shown. Then wrap pad bungee around the vertical leg piece.

Assembly and Installation Instructions

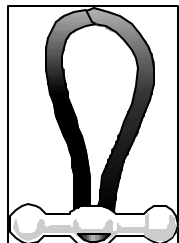

Bungee T-anchor

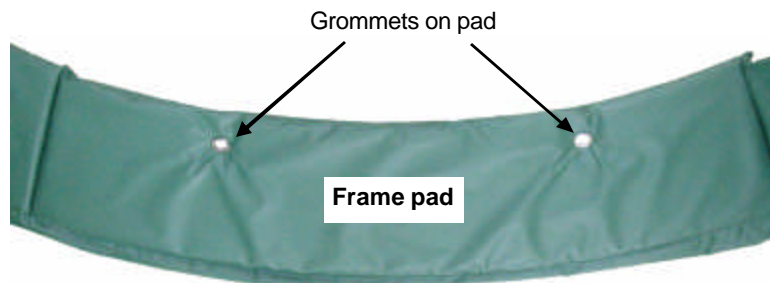

5) See your safety enclosure user's manual to properly attach bungee T-anchors through the grommets on top of the pad. T-anchors should pass through grommets on pad before securing to V-rings on trampoline mat.

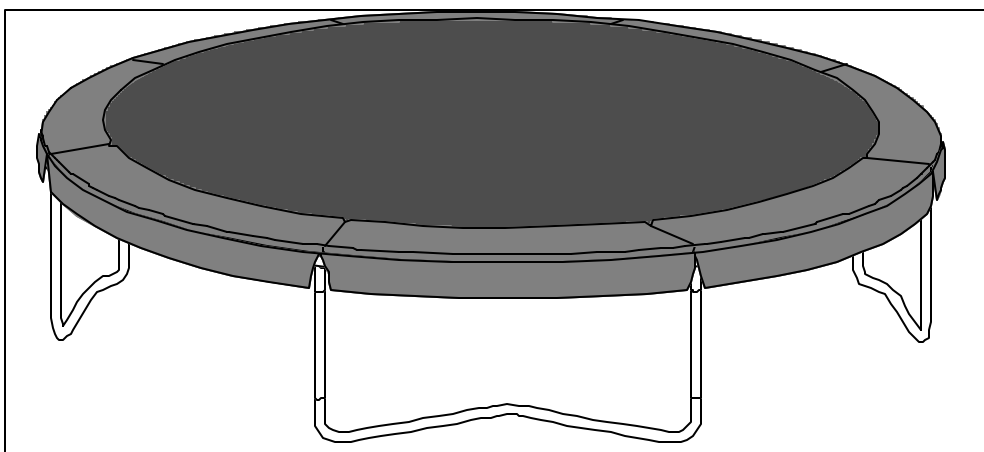

Your 14ft Deluxe Universal Frame Pad is now installed!
To remove the frame pad, follow the Installation Instructions in reverse order.

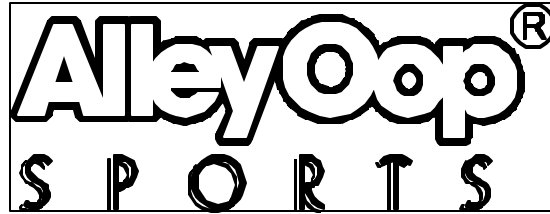

1 Year Limited Warranty

What is covered by this warranty? This warranty covers any defects in materials or workmanship on all of the components of the AlleyOop Sports 14ft Deluxe Universal Frame Pad, and is extended exclusively to the original retail purchaser.

How long does this coverage last? Warranty coverage for each component begins from the original date of purchase and lasts for 1 year.

What will AlleyOop Sports do? If you return the defective part to AlleyOop Sports, as instructed below, AlleyOop Sports will either repair or replace such part, at AlleyOop Sports' discretion, and return it to you.

What is not covered by this warranty? This warranty does not cover expenses of on-site labor, travel, assembly or disassembly, or other charges associated with the repair or replacement of covered components. This warranty also does not cover any problem that is caused by abuse, misuse, commercial or public use, ordinary wear and tear, weathering, acts of God (such as wind and lightning), failure to follow directions, improper installation, or improper maintenance.

ALLEYOOP SPORTS IS NOT RESPONSIBLE OR LIABLE FOR INDIRECT, SPECIAL, OR CONSEQUENTIAL DAMAGES ARISING OUT OF OR IN CONNECTION WITH THE USE OR PERFORMANCE OF THE PRODUCT OR OTHER DAMAGES WITH RESPECT TO ANY LOSS, INCLUDING BUT NOT LIMITED TO ECONOMIC LOSS, LOSS OF PROPERTY, LOSS OF REVENUE OR PROFITS, LOSS OF ENJOYMENT OR USE, COST OF REMOVAL, INSTALLATION OR OTHER CONSEQUENTIAL DAMAGES. SOME STATES DO NOT ALLOW THE EXCLUSION OR LIMITATION OF INCIDENTAL OR CONSEQUENTIAL DAMAGES. ACCORDINGLY, THE ABOVE LIMITATION MAY NOT APPLY TO YOU.

THE WARRANTY EXTENDED HEREUNDER IS IN LIEU OF ALL OTHER WARRANTIES AND ANY IMPLIED WARRANTY OF MERCHANTABILITY OR FITNESS FOR A PARTICULAR PURPOSE IS LIMITED IN ITS SCOPE AND DURATION TO THE TERMS SET FORTH HEREIN. SOME STATES DO NOT ALLOW LIMITATIONS ON HOW LONG AN IMPLIED WARRANTY LASTS. ACCORDINGLY, THE ABOVE LIMITATION MAY NOT APPLY TO YOU.

How to get a defective part replaced:

- 1) Call the AlleyOop Sports Customer Service department at 408-213-2551 to obtain a Return Authorization number. All returns must be pre-authorized.
- 2) Send the part(s) to the designated Service Center, along with a copy of your original sales receipt and a brief written description of the problem, including how it occurred. You must pay freight and insurance to return the part to AlleyOop Sports. At AlleyOop Sports' sole discretion, we may ask you to send photographs in addition to or in lieu of returning the part.
- 3) After inspecting the returned part(s), AlleyOop Sports will make a final determination whether the part is covered by this warranty. We reserve the right to examine photographs or physical evidence concerning parts claimed to be defective prior to making a final determination concerning the claim. A repaired or replacement part will be returned to you. Please allow 3 to 4 weeks for delivery.

This warranty gives you specific legal rights. You may also have other rights which vary from state to state.

JumpSport, Inc.
2055 South 7th Street, Suite A
San Jose, CA 95112

408-213-2551

<http://www.jumpsport.com>