

# JumpSport®

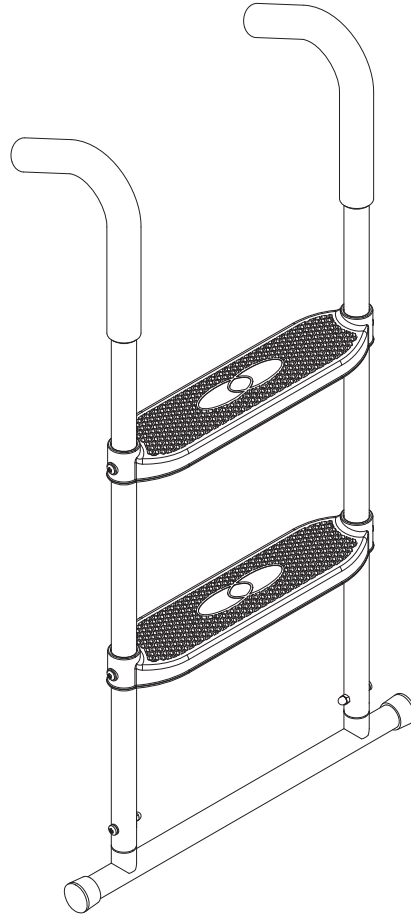

## SureStep Trampoline Ladder (2 Step) Installation Instructions

### **⚠ WARNING**

- Ladder lets young children climb onto trampoline.
- Trampolines not for children under 6 years.
- Do not use ladder if children under six might be nearby.
- Remove when trampoline is not in use.

Retain address information for future use.

JumpSport, Inc.  
2055 South 7th Street, Suite A  
San Jose, CA 95112 U.S.A.

408-213-2551  
[www.jumpsport.com](http://www.jumpsport.com)

## Copyright Notice

This material is protected by United States copyright laws and is proprietary to JumpSport, Inc. Disclosure, reproduction, translation, modification, or use of this document by anyone other than authorized employees, authorized users, or licensees of JumpSport without the prior written consent of JumpSport, Inc. is prohibited.

The information in this document is subject to change without notice. JumpSport, Inc. shall not be liable for any damages resulting from technical errors or omissions, which may be present in this document, or from use of this document.

Copyright © 2003-2011, by JumpSport, Inc. All rights reserved.

Printed: 2011

Instruction Manual P/N: INS-P-10630E

JumpSport SureStep Trampoline Ladder P/N: LAJ-S-10629A

## Trademarks

JumpSport® and SureStep™ Trampoline Ladder are trademarks of JumpSport, Inc.

All other brand or product names are trademarks or registered trademarks of their respective companies or organizations.

## How to Contact Customer Support

Should you require customer service or technical support for your JumpSport SureStep Trampoline Ladder, please contact JumpSport's Customer Service department at:

United States:

408-213-2551

6:00am – 5:00pm Monday through Friday, Pacific Time

Australia:

1800-822-117



# Assembly and Installation Instructions

---

## **WARNING**

- Ladder lets young children climb onto trampoline.
- Trampolines are not for children under 6 years of age.
- Do not use ladder if children under 6 might be nearby.
- Remove ladder when trampoline is not in use in order to prevent access by children under 6.

The following page contains diagrams and written instructions for installing your SureStep Trampoline Ladder.

*Familiarize yourself with the Assembly and Installation Instructions before beginning installation.*

**Note:** *This SureStep Trampoline Ladder is designed to fit trampolines that are 33 to 37 inches tall.*

# Assembly and Installation Instructions

**Diagram 1**

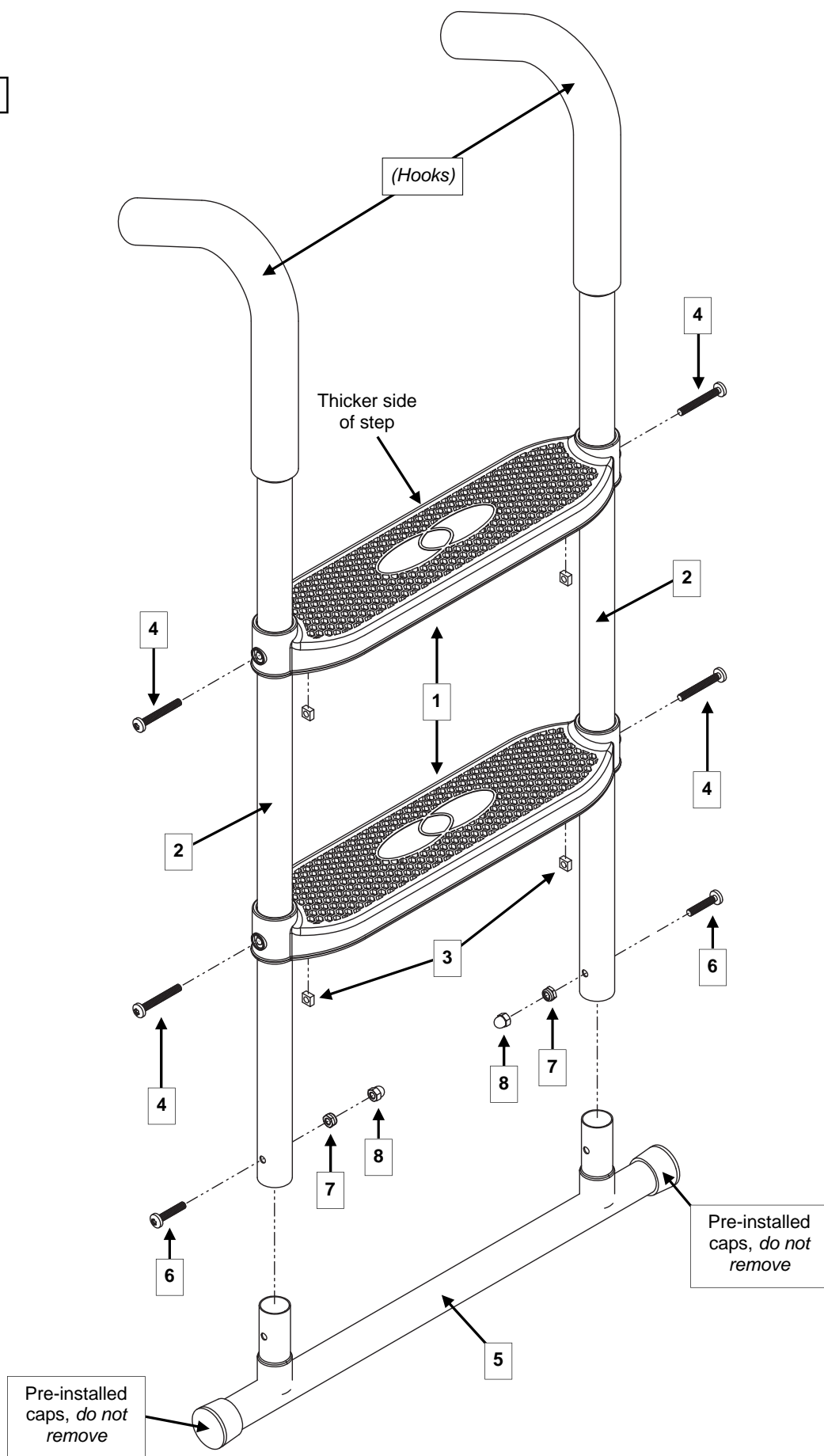

## Assembly and Installation Instructions

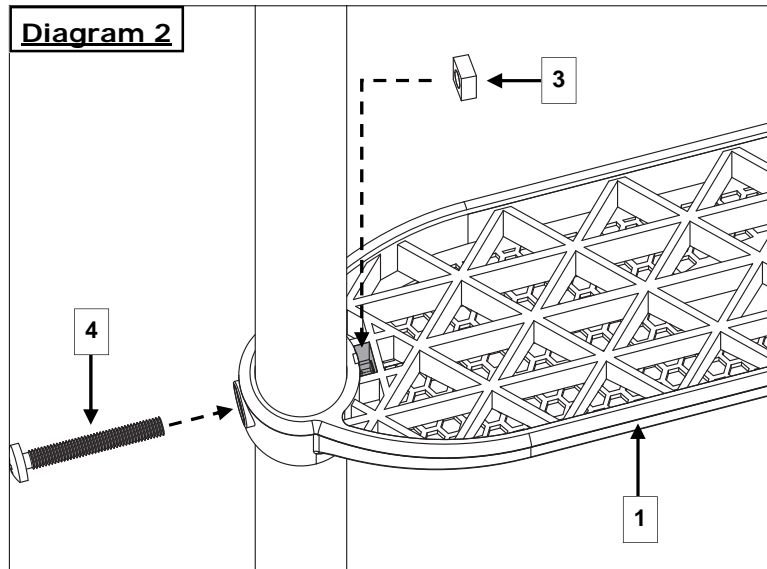

(Under side of step, showing square nut location)

Reference #	Description	Quantity
1	Step	2
2	Vertical side piece	2
3	Square nut	4
4	M6 screw, long	4
5	Horizontal base	1
6	M6 screw, short	2
7	Nylock nut, 10mm	2
8	Acorn nut	2

**Note:** You will need a Phillips screwdriver & and a 10mm wrench (not included) to install your SureStep Trampoline Ladder.

**1)** Slide steps into place along vertical side pieces. Install square nuts (see Diagram 2), then loosely tighten *long* M6 screws with a Phillips screwdriver.

**Note:** The top of each step is angled. The thinner side needs to face out (away from the hooked ends on the top of the vertical side pieces) and the thicker side needs to face in (toward the hooks).

**2)** Slide horizontal base into place. Then loosely tighten *short* M6 screws and Nylock nuts together, using a Phillips screwdriver and a 10mm wrench.

**3)** Tighten *long* (step) screws snugly. Do not over-tighten.

**4)** Tighten *short* (base) screws snugly. Do not over-tighten. Then hand-tighten acorn nuts over ends of screws.

**5)** After ladder is completely assembled, hook it over top rail of trampoline, under frame pad.

**Your SureStep Trampoline Ladder is now complete!**

## Assembly and Installation Instructions

*(This page left intentionally blank.)*

# JumpSport®

## 90 Day Limited Warranty

**What is covered by this warranty?** This warranty covers any defects in materials or workmanship on all of the components of the JumpSport SureStep Trampoline Ladder, and is extended exclusively to the original retail purchaser.

**How long does this coverage last?** Warranty coverage for each component begins from the original date of purchase and lasts for 90 days.

**What will JumpSport do?** If you return the defective part to JumpSport, as instructed below, JumpSport will either repair or replace such part, at JumpSport's discretion, and return it to you.

**What is not covered by this warranty?** This warranty does not cover expenses of on-site labor, shipping costs, travel, assembly or disassembly, or other charges associated with the repair or replacement of covered components. This warranty also does not cover any problem that is caused by abuse, misuse, commercial or public use, ordinary wear and tear, weathering, acts of God (such as wind and lightning), failure to follow directions, improper installation, improper maintenance, or any silk screened graphics. Rust is a natural occurrence with any outdoor steel product and is likewise not covered by this warranty, to the extent that it does not affect the structural integrity of the part.

JUMPSPORT IS NOT RESPONSIBLE OR LIABLE FOR INDIRECT, SPECIAL, OR CONSEQUENTIAL DAMAGES ARISING OUT OF OR IN CONNECTION WITH THE USE OR PERFORMANCE OF THE PRODUCT OR OTHER DAMAGES WITH RESPECT TO ANY LOSS, INCLUDING BUT NOT LIMITED TO ECONOMIC LOSS, LOSS OF PROPERTY, LOSS OF REVENUE OR PROFITS, LOSS OF ENJOYMENT OR USE, COST OF REMOVAL, INSTALLATION OR OTHER CONSEQUENTIAL DAMAGES. SOME STATES DO NOT ALLOW THE EXCLUSION OR LIMITATION OF INCIDENTAL OR CONSEQUENTIAL DAMAGES. ACCORDINGLY, THE ABOVE LIMITATION MAY NOT APPLY TO YOU.

THE WARRANTY EXTENDED HEREUNDER IS IN LIEU OF ALL OTHER WARRANTIES AND ANY IMPLIED WARRANTY OF MERCHANTABILITY OR FITNESS FOR A PARTICULAR PURPOSE IS LIMITED IN ITS SCOPE AND DURATION TO THE TERMS SET FORTH HEREIN. SOME STATES DO NOT ALLOW LIMITATIONS ON HOW LONG AN IMPLIED WARRANTY LASTS. ACCORDINGLY, THE ABOVE LIMITATION MAY NOT APPLY TO YOU.

**How to get a defective part replaced:**

- 1) Call the JumpSport Customer Service department at 408-213-2551 to obtain a Return Authorization number. All returns must be pre-authorized.
- 2) Send the part(s) to the designated Service Center, along with a copy of your original sales receipt and a brief written description of the problem, including how it occurred. You must pay freight and insurance to return the part to JumpSport. At JumpSport's sole discretion, we may ask you to send photographs in addition to or in lieu of returning the part.
- 3) After inspecting the returned part(s), JumpSport will make a final determination whether the part is covered by this warranty. We reserve the right to examine photographs or physical evidence concerning parts claimed to be defective prior to making a final determination concerning the claim. A repaired or replacement part will be returned to you. (Shipping charges may apply.) Please allow 3 to 4 weeks for delivery.

This warranty gives you specific legal rights. You may also have other rights which vary from state to state.

**JumpSport, Inc.**  
**2055 South 7th Street, Suite A**  
**San Jose, CA 95112**

**408-213-2551**

**<http://www.jumpsport.com>**