



WARNING



1. DO NOT attempt somersaults. Landing on your head or neck can cause serious injury, paralysis, or death, even when landing in the middle of the bed.
2. DO NOT allow more than one person on the trampoline at a time. Use by more than one person at the same time can result in serious injuries.
3. Use trampoline only with mature, knowledgeable supervision.
4. Trampolines over 20 in. (51 cm) tall (including this trampoline) are NOT recommended for use by children under 6 years of age.
5. Inspect the trampoline before each use. Make sure the frame padding is correctly and securely positioned. Replace any worn, defective or missing parts.
6. Climb on and off the trampoline. It is a dangerous practice to jump from the trampoline to the floor or ground when dismounting, or to jump onto the trampoline when mounting. Do NOT use the trampoline as a springboard to other objects.
7. Stop your bounce by flexing your knees as your feet come in contact with the trampoline bed. Learn this skill before attempting others.
8. Learn fundamental bounces and body positions thoroughly before trying more advanced skills. A variety of trampoline activities can be carried out by performing the basic fundamentals in various series and combinations, performing one fundamental after another, with or without feet bounces between them.
9. Avoid bouncing too high. Stay low until you can control your bounce and repeatedly land in the center of the trampoline. Control is more important than height.
10. Focus your eyes on the perimeter of the trampoline. This will help control your bounce.
11. Avoid bouncing when tired. Keep turns short.
12. Properly secure the trampoline when not in use. Protect it against unauthorized use. If a trampoline ladder is used, the supervisor should remove it from the trampoline when leaving the area to prevent unsupervised access by children under 6 years of age.
13. Keep objects away which could interfere with the performer. Maintain a clear area around the trampoline.
14. Do not use the trampoline while under the influence of alcohol or drugs.
15. For additional information concerning the trampoline equipment, contact the manufacturer.
16. For information concerning skill training, contact a certified trampoline instructor.
17. Bounce only when the surface of the bed is dry. Wind or air movement should be calm to gentle. The trampoline must not be used in gusty or severe winds.
18. Read all instructions before using the trampoline. Warnings and instructions for the care, maintenance and use of this trampoline are included to promote safe, enjoyable use of this equipment.



ATTENTION



It is the responsibility of the purchaser to become familiar with all of the information in this booklet, to convey the warnings to all users, and to enforce the manufacturers rules for safe use.

This unit is not intended for commercial or public use; and is therefore, strictly prohibited.

Trampolines, being rebounding devices, propel the performer to unaccustomed heights and into a variety of body movements. Therefore, it is emphasized that all purchasers, and all persons using the trampoline, become familiar with the rules for safe use. Misuse and abuse of this trampoline is dangerous, and can cause serious injuries. The purchaser/user of this piece of equipment is assuming a degree of risk for which the manufacturer cannot be responsible.

On the following pages are articles of information relative to the proper installation and safe operation of the trampoline. This information is a system of:

Warnings and Cautionary Statements
Homeowner Inspection, Care and Maintenance
Trampoline Placement and Assembly Instructions
Points of Safety
Basic Skills and Instructional Materials
Warranty, Repair, and Returns Procedures

Read this information thoroughly before allowing the trampoline to be used. Keep this manual available for your review, and for review by all potential users. If there are questions please telephone the manufacturer for further explanation. The phone number is 1-408-213-2551, hours are 8:00am – 5:00pm Monday through Friday, Pacific Time.

JumpSport, Inc.
P.O. Box 2446
Saratoga, CA 95070
1-408-213-2551

JumpSport®

Staged-Bounce™ Trampoline

14 Foot

Model 1440

Featuring the Sure-Lok™ frame system

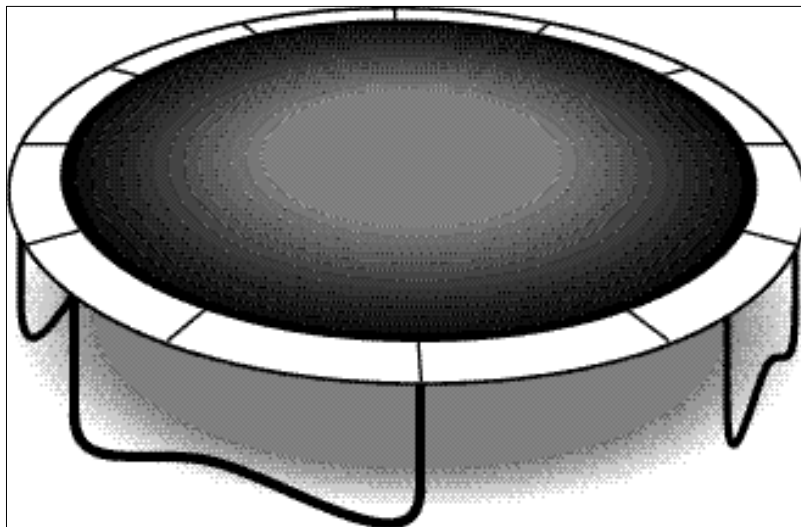
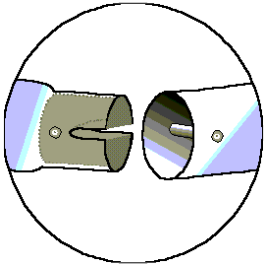

...and Staged-Bounce™ Technology.

US Patent No. 6,840,891 and Patents Pending

U
S
E
R
'
S

M
A
N
U
A
L

Assembly, Installation, Care, Maintenance, and Use Instructions



WARNING



Do not attempt or allow somersaults. Landing on your head or neck can cause serious injury, paralysis or death, even when landing in the middle of the bed.



Do not allow more than one person on the trampoline at a time. Use by more than one person at the same time increases the chance of injury.

**Read these materials prior to assembling and using this trampoline.
Maximum user weight: 235 pounds**



CAUTIONARY STATEMENT



JumpSport® Trampolines are designed exclusively for the home backyard market. The vast majority of users of our trampolines are children, and therefore need close supervision and rules to follow while playing on the trampoline. These rules must be enforced by whomever is responsible for the care of the children. It is strongly recommended that the buyer of this product go over the rules and recommendations in the packet of information supplied, including those in this manual. It is also strongly recommended that these rules and recommendations be supplemented with those of your own (e.g., the time that jumping is allowed, when neighbors can visit, etc., and that these rules and recommendations be reviewed with anyone who is going to jump on the trampoline). If it is possible, these rules should be reviewed with the parents or guardians of any visitors who may be jumping on the trampoline. (See page 13 for Points of Safety).

Recommended weight limitation is no more than 235 lbs. Persons at, or near this weight should test the resiliency of the springs prior to extensive bouncing. Do this by jumping lightly on the mat. If the resiliency appears to be weak (bed does not lift the individual when light jumps are made), discontinue bouncing immediately, take off the springs and inspect them. If the springs appear to be stretched out of shape, the mat should not be put back on until the springs have been replaced. Be sure to check the mat for any areas that need restitching, or “V” rings that may need replacing.



Due to the risks associated with users falling off of trampolines, we strongly urge you to use a JumpSport® Safety Enclosure in conjunction with your trampoline. Please call JumpSport if you have any questions about such a device.



We also urge you to not keep any ladder, step stool, or other climbing device next to the trampoline when use of the trampoline is not supervised by an adult. This precaution helps to prevent access to the trampoline by individuals that are too small, and/or do not have the physical strength necessary to jump on a trampoline without having the proper supervision.

Table of Contents

The JumpSport® Safety Enclosure.....	4
<u>Assembly:</u>	
Trampoline Placement.....	5
Assembly Instructions.....	6-9
<u>Care & Maintenance:</u>	
Homeowner: Inspection, Protection, Maintenance Procedures, and Repairs.....	10
Care and Maintenance.....	11
Care and Maintenance Check List.....	12
<u>User Instructions:</u>	
Points of Safety - Warnings.....	13
Basic Trampoline Skills	
Bouncing.....	14
Arm Action.....	14
Bounce Variations.....	14
Basic Landing Positions	
Seat Drop.....	15
Hands and Knees Drop.....	15
Front Drop.....	15-16
Beginning Twisting.....	16
Seat Drop, Half Twist, Seat Drop (Swivel Hips).....	16
Front Drop, Half Twist, Front Drop (Turn Table).....	16
Seat Drop, Full Twist to Seat Drop (Barrel Roll).....	17
Additional Twisting.....	17
Warranty Information.....	Last Page

JumpSport® Safety Enclosure

Congratulations on purchasing a JumpSport® trampoline! We sincerely believe that you have purchased the finest round trampoline on the market. It has been engineered with safety, durability, and performance in mind. As a result, this product features our Staged-Bounce™ mat system.

Studies show that many of the injuries associated with trampoline use in a residential setting are a result of the user falling off of the trampoline and hitting the ground or some other object. For this reason, it is strongly recommended that a **JumpSport® Safety Enclosure** be used in conjunction with your trampoline. The JumpSport safety enclosure should be used as a supplement to mature, knowledgeable supervision – **not a substitute**. The JumpSport enclosure can also be locked to prevent unauthorized use. Please contact your local JumpSport dealer to learn more about the safety enclosure, or call JumpSport directly.

Protect your trampoline with a

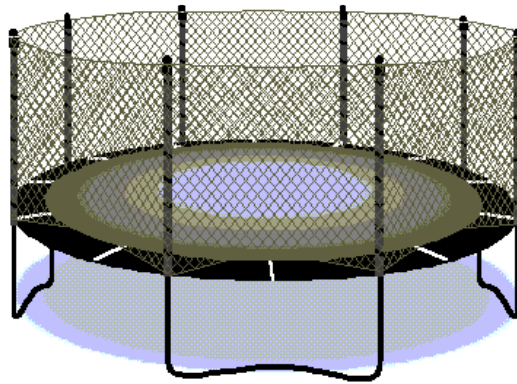

JumpSport® Safety Enclosure

U.S. Patent #6053845, 6261207 and Patents Pending

Safe use of a trampoline also requires adequate knowledge of technique, as well as what *not* to do. Please read this manual thoroughly for key points of safety.

TRAMPOLINE PLACEMENT

Adequate **overhead clearance** is *essential*. A minimum of 24 feet (7.3 meters) is recommended from ground level. Provide clearance for wires, tree limbs, and other possible hazards.

Lateral clearance is *essential*. Place the trampoline away from walls, structures, fences, pools, and other play areas. Maintain a **clear space** on all sides of the trampoline.

Place the trampoline on a **level surface** before use.

Use the trampoline in a **well-lighted area**. Artificial illumination may be required for indoor or shady areas.

Secure the trampoline against unauthorized and unsupervised use.

Remove any obstructions from beneath the trampoline.

The owner and supervisors of the trampoline are **responsible** to make all users aware of practices specified in the **User Instructions** section of the manual.

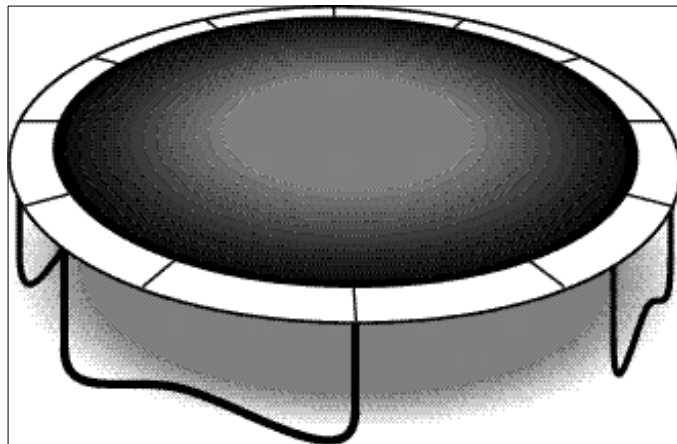

ASSEMBLY INSTRUCTIONS

Read through all assembly steps carefully before beginning the assembly process. Refer to drawings for clarification.

Assembly requires use of one 1/2" and one 9/16" wrench (or adjustable wrenches). Safety Glasses and Gloves are recommended during the assembly procedure.

STEP 1:

Lay out all frame sections in a circle as shown (see Figure 1). Verify inventory of each part.

Trampoline inventory consists of these components:

- 1) Top rail with left leg socket [TR-RAI-J-0320R1] – 4 pieces
- 2) Top rail with right leg socket [TR-RAI-J-0322R1] – 4 pieces
- 3) Top rail with no leg socket [TR-RAI-J-0321] – 4 pieces
- 4) Left vertical leg piece [TR-LEG-KJ-0717] – 4 pieces
- 5) Right vertical leg piece [TR-LEG-KJ-0718] – 4 pieces
- 6) Horizontal leg piece [TR-LEG-J-0057] – 4 pieces
- 7) Nuts [TR-NUT-J-0052] and Bolts [TR-BOL-J-0051] – 8 sets
- 8) Springs [TR-SPR-X-0067] -96 pieces (boxed separately)
- 9) Jumping Mat/Bed [TR-MAT-J-0342] – 1 piece
- 10) Frame Pad half [TR-PAD-J-0714] – 2 pieces
- 11) Short elastic cords to join pad sections [TR-BUN-X-0290] – 6 pieces
- 12) Long elastic cords [TR-BUN-J-0566] – 8 pieces
- 13) Warning Placard [TR-WRN-J-0136] – 1 piece

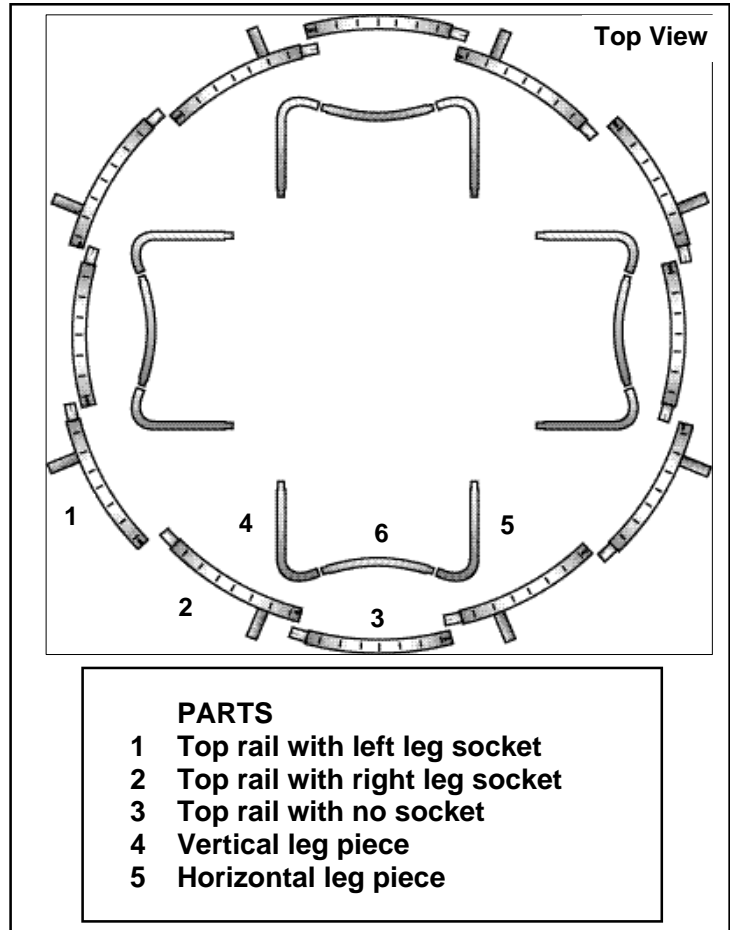

FIGURE 1

If you are missing any parts, call 1-408-213-2551.

Note: All top rail pieces have one smaller end. The smaller end should be facing the same **direction (clockwise)** for all parts when laid out correctly.

Important: The components must be laid out in the **pattern** shown for the trampoline to be assembled correctly.

STEP 2:

Assemble all top rail pieces of the trampoline to form a ring

For maximum fit and performance, all rail pieces include the Sure-Lok™ frame system. Assembly consists of aligning the “key way” on the small end of one section into the “key” on the larger end of the adjacent section (see Figure 2).

Note: When joining the last two sections of the ring, it may be helpful to have someone stand on the opposite side of the ring while the assembler pushes inwards on the frame and joins the two.

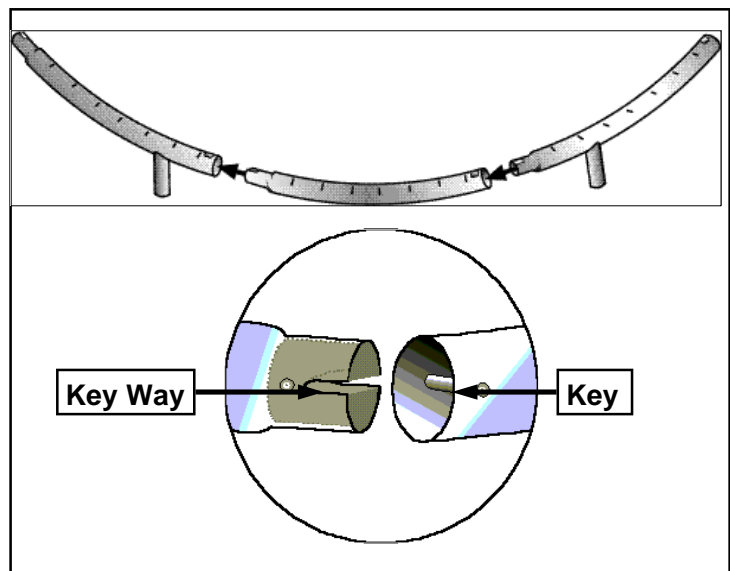

FIGURE 2

STEP 3:

Build each leg assembly

A left vertical leg piece is “L-shaped” when the snap button at the top is facing away from view, and a right vertical leg piece will be “J-shaped.” Join one left, right, and horizontal leg piece to make a **leg assembly** (see Figure 3). Make sure that the buttons at the top of each leg are facing the same direction. Join the assembly tubes by installing bolt and nut at each joint. Tighten with wrenches but do not over-tighten. Repeat with the remaining leg pieces.

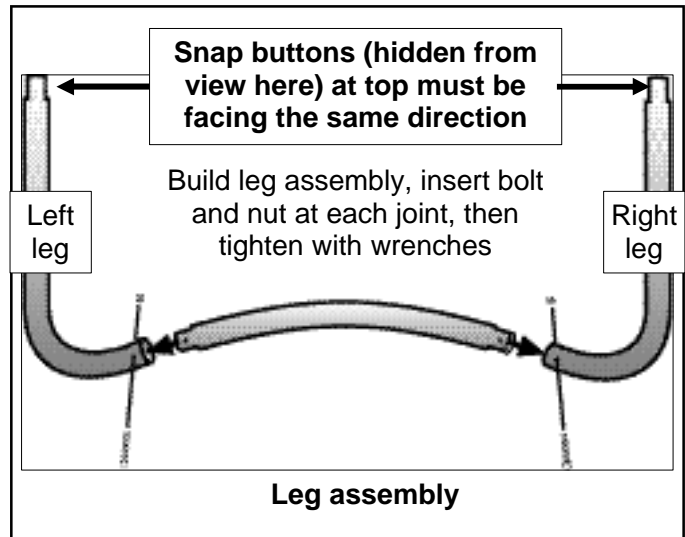

FIGURE 3

STEP 4:

Lift frame (ring) and install leg assemblies

At this point, you may need someone to assist you with the assembly. Before performing this step, orient each leg assembly so that the snap buttons at the top of each end face in towards the center of the trampoline (if applicable). As one person lifts one side of the trampoline ring, another should lift a **leg assembly** to a vertical position and insert one end into a socket on the ring (see Figure 4). With one end installed, install the other end of the leg assembly into the appropriate leg socket. For ease of assembly, the first end should be about 1/2 inch into the socket when installing second end. Snap legs into place (if applicable).

Note: Each leg assembly should have a top rail piece with no leg sockets in the middle of its two vertical leg pieces (see Figure 4). Bolt heads of the leg assemblies should be facing the outside of the trampoline. Repeat installation of leg assembly on the opposite side of the trampoline, then at the two remaining locations.

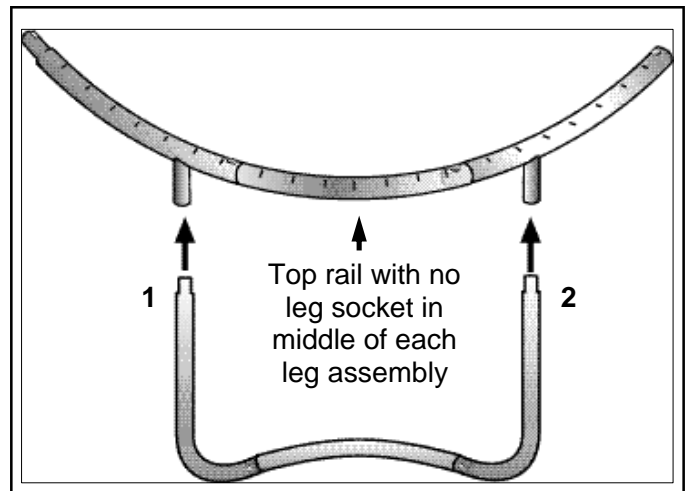

FIGURE 4

STEP 5:

Hints Before Installing Springs

Since you have purchased the Staged-Bounce™ trampoline, you will note that one half of the connection points on the mat have a small “V” rings, and one half have large “V” rings. This combination results in a more forgiving bed at initial impact, because the springs provide less resistance at that time.

It may be helpful in the following steps to note that springs are most readily stretched into place with the aid of another spring. To do so, hook the spring you want to install to a “V” ring on the bed. Use another spring as a tool by connecting the second spring to the free end of this spring. Holding the second spring with one hand, pull the spring being installed toward the frame. When the spring being installed reaches the frame, hook it into the hole on the frame, and unhook the second spring (see Figure 5).

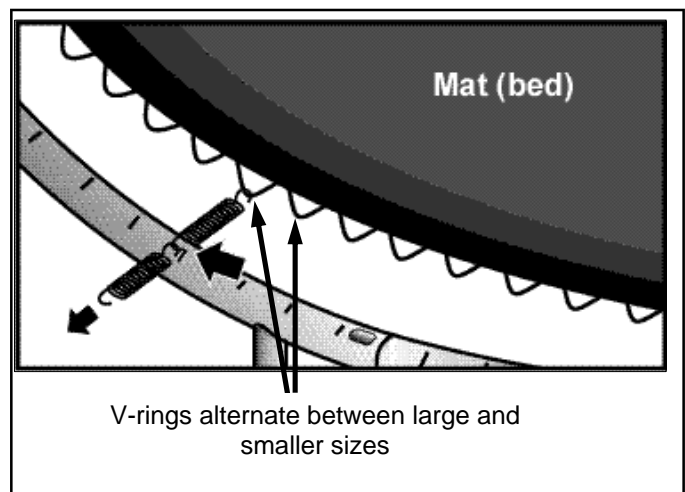

FIGURE 5

STEP 6:

Install springs at every 4th hole and V ring

Lay the jumping mat (bed) inside the frame with the warning labels facing up. Springs (boxed separately) are used to support the mat (bed) and are connected between "V" rings on the mat and holes in the top frame rail. Select a hole on the frame near one leg, and connect a spring between the V ring and the frame hole at this point. Count 4 holes on the frame (and 4 V rings) to the left (clockwise), and connect another spring. See step 5 for easier spring assembly. (Between spring one and two, there will be 3 empty holes and V rings.) Follow this procedure all the way around the trampoline (at 24 locations in total – see Figure 6).

Be sure to count holes and V rings accurately. If the count is off, go to where the correct pattern was stopped, and begin again.

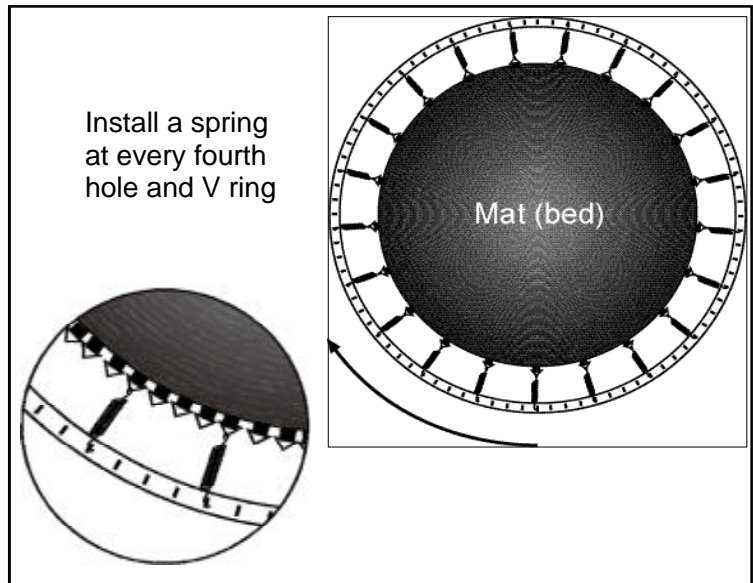

FIGURE 6

STEP 7:

Install springs to the middle hole of every section

Between each of the 24 springs, there will be three empty holes and V rings. Working clockwise all the way around the trampoline, connect a spring at every **middle** V ring to the appropriate hole (see Figure 7).

STEP 8:

Complete installation of the mat

Install the remaining springs clockwise to complete the installation of the bed.

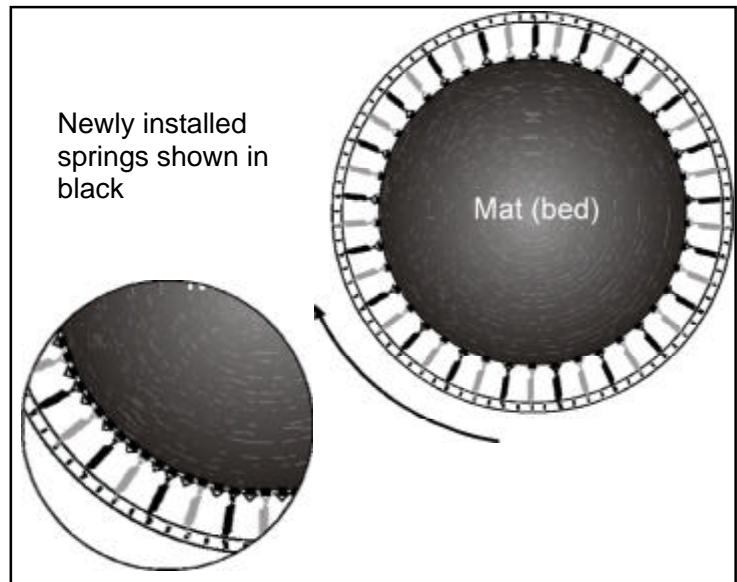

FIGURE 7

STEP 9:

Layout, align, and join frame pad pieces

Lay pad pieces over frame. Align notches in skirt with sockets at each leg. Plastic connectors should be on the underside of mat. Join pieces of pad using short elastic cords (three at each joint). Do not use the connectors closest to the outside edge of the pad for this step (see Figure 9). Do **NOT** tie the pads tightly together, or the pads may tear.

STEP 10:

Attach pad to frame of trampoline

There will be two plastic anchors on the underside of the pad near each leg of the trampoline. Connect pad to leg by feeding long elastic cords through both connectors and then tying around each leg (Figure 10). Do **NOT** tie the pads tightly around the legs, or they may tear. Connect sections of skirt at joints also with long elastic cords. Cut ends if necessary to remove excess. Again, do **NOT** tie the pads tightly, or they may tear.

IMPORTANT: Make sure that the pad is installed properly over the frame and the springs before use.

STEP 11:

Attach warning placard to trampoline

Attach the safety instruction placard using the enclosed cable (zip) tie. Place placard at the point where you will normally mount the trampoline so that it is visible, and attach to top rail with cable tie.



ASSEMBLY IS NOW COMPLETE

Make sure that all parts are securely assembled. Familiarize yourself and all users of the trampoline with the care and maintenance instructions, use and instructional materials, and safety precautions contained in this manual before using the trampoline.

DISASSEMBLY

To disassemble, follow the assembly steps in reverse order. Do not attempt to disassemble any frame components before the mat (bed) and springs have been removed.

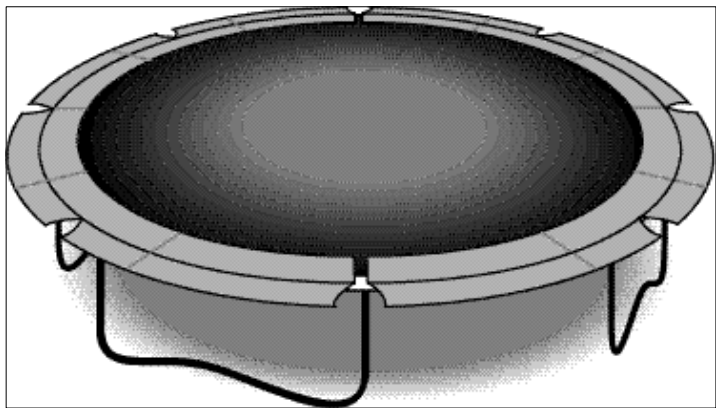

FIGURE 8

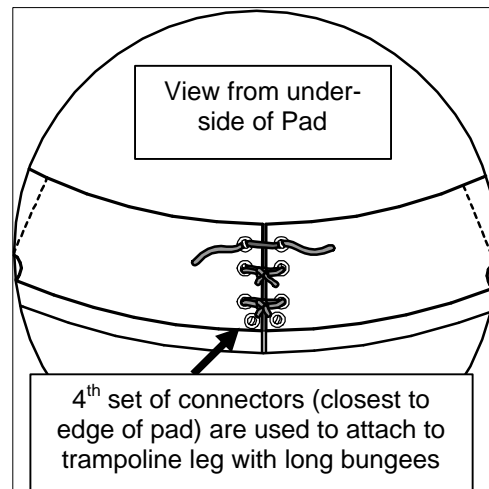

FIGURE 9

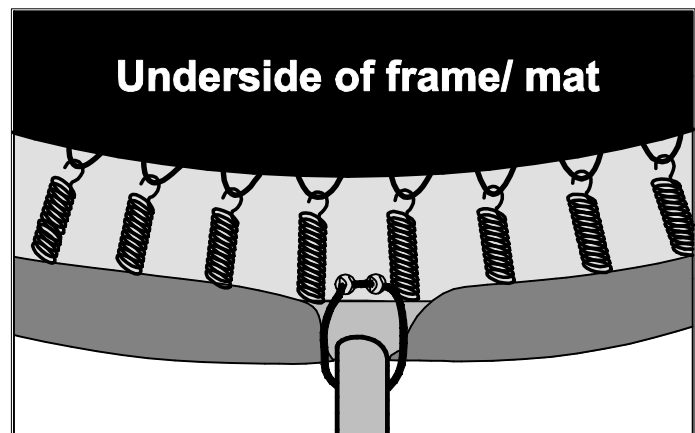
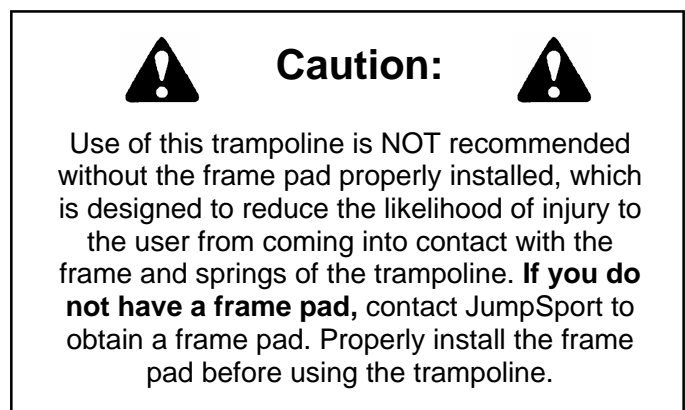

FIGURE 10



HOMEOWNER: INSPECTION, PROTECTION, AND MAINTENANCE PROCEDURES

All trampolines require maintenance at some time. Springs may need to be replaced, frame parts may become bent, stitching in the mat and safety pads may rot out.

Inspect the trampoline before each use and replace any worn, defective, or missing parts.

The following conditions could represent potential safety hazards:

1. Missing, improperly positioned or insecurely attached frame padding
2. Punctures, frays, tears or holes worn in the bed or frame padding
3. Deterioration in the stitching or fabric of the bed or frame padding
4. Over-stretched springs
5. A bent or broken frame
6. A sagging bed (black mat)
7. Sharp protrusions on the frame or suspension system

An item that poses one of the greatest hazards is worn out or rotten stitching around the jumping mat (the black bed). **STITCHING MAY FAIL WITHIN 2 TO 3 YEARS OR EARLIER, DUE TO EXCESSIVE USE OR EXPOSURE TO EXTREME WEATHER.** In most cases where deterioration has begun, evidence will make itself known in the form of broken stitches at the straps or as rotting, frayed straps at the position of the v-ring. **When this is found, all bouncing must cease and the trampoline immediately disassembled. The jumping mat should be replaced with the appropriate JumpSport® mat.** Remember, the only thing between the jumper and the ground is the mat. If a deteriorated mat is not inspected properly, jumping can cause the mat to pull away from the straps in a large area so that the jumper may land on the ground. This could cause a serious injury.

This trampoline is designed for year-round outdoor use. However, in climates of cold weather where snow and ice is prevalent, we recommend the mat be taken off and stored in a dry area. To remove the mat, simply reverse the assembly instructions for installing it. (See page 9-10).

During an ice or snow storm, you should use extreme care in removing the ice and snow in order to remove the mat. We suggest using a high pressure water hose and spray upward from the underside of the trampoline starting at the mat's lowest point. Another recommendation is to use hot water on the ice and snow to melt it away such that the mat can be removed.

Left unattended in snow and ice, your trampoline jumping mat will accumulate weight in the middle causing damage to your springs. ***This type of damage is not covered by your warranty.***

In removing the snow and ice be sure to not use any type of sharp object such as a shovel, hoe, or garden rake to remove the ice as this may cause damage to your mat. ***This type of damage is not covered by your warranty.***

INSPECT YOUR TRAMPOLINE BEFORE EACH USE. If any materials are found defective, worn, or missing then jumping should be prohibited until the trampoline is repaired. If any warning labels or signs become unreadable or missing, call JumpSport for free replacements.

REPLACEMENT PARTS

All replacement parts should be ordered through JumpSport. Shoe shops, awning and tent companies, or upholsterers do not have the proper materials, equipment and methods for proper, safe repair of trampoline mats and safety pads. Call **JumpSport®** for a Return Authorization number for proper replacements 1-408-213-2551.

Trampoline beds should be replaced in total should any tear or hole be greater than 1 inch in length or diameter. Patches over larger holes will eventually fail creating a potential for hazardous injuries. **DO NOT REPAIR MATS WITH HOLES GREATER THAN 1 INCH.**

CARE AND MAINTENANCE

CARE

Do not allow family **pets** on the trampoline, as claws may snag and pull the mat (bed) material or damage the frame pad.

The trampoline is intended to be used **by one person at a time**, weighing less than 235 pounds. The user should be either barefoot, or wearing gymnastic slippers or non-cleated athletic shoes. The user should remove all sharp objects from their person which may cause injury or damage to the trampoline mat (bed). Heavy, sharp or pointed hard objects should not contact the mat (bed) surface.

MAINTENANCE

Your trampoline is manufactured using quality materials and is finely-crafted to provide you and your family with many years of enjoyment and exercise. Proper maintenance and care will help to prolong the life of the trampoline and reduce the possibility of injury. The following guidelines should always be observed.

Inspect the trampoline before each use and replace any worn, defective or missing parts. The following conditions present potential hazards and increase the danger of personal injury.

- a. Missing, improperly positioned, or insecurely attached frame padding
- b. Punctures, frays, tears, or holes worn in the bed or frame padding
- c. Deterioration in the stitching or fabric of the bed or frame padding
- d. Over-stretched springs
- e. A bent or broken frame
- f. Sagging jumping mat (bed)
- g. Sharp protrusions on the frame or suspension system

IF ANY OF THESE CONDITIONS EXIST, THE TRAMPOLINE SHOULD BE DISASSEMBLED OR OTHERWISE PROTECTED AGAINST USE UNTIL THE CONDITION IS REMEDIED.

SPECIAL CONSIDERATIONS

WIND

It is possible for the trampoline to be blown about by a high wind. If you anticipate high winds, the trampoline should be moved to a sheltered location, disassembled, or the top of the frame should be secured to the ground with the use of a trampoline anchor kit. The anchor kit can be found at www.jumpsport.com

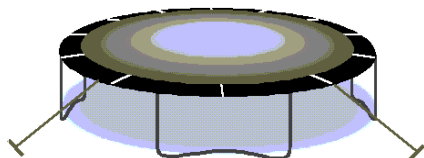

Use a JumpSport® trampoline anchor kit to tie down the trampoline. **Make sure the ends of the stakes are protected and the ropes are visible to users.**

MOVING THE TRAMPOLINE

If you need to move your trampoline periodically, it should be moved by at least two people, **kept horizontal and lifted slightly to move**. Disassemble the trampoline for any other type movement.

CARE & MAINTENANCE SAFETY CHECK LIST

IMPORTANT: Inspect the trampoline before using and replace any worn, defective, or missing parts.

FRAME PADS: Our pad reduces the risk of accidental injury due to falling onto the frame railing and gives minimal resistance to striking or falling onto and through the springs. Frame pad life expectancy is one to two years. To increase life of pad: 1) Do not allow jumpers to stand or sit on pad; 2) Do not allow jumpers to grab pad in order to pull themselves onto trampoline; 3) Do not allow sharp, abrasive objects to come in contact with the pad surface.

Check for:	Necessary Action	Safety Check	
		Safe	Unsafe
Vinyl Deterioration	Replace	_____	_____
Foam Deterioration	Replace	_____	_____
Missing Pads	Replace	_____	_____
Improperly Attached Pads	Reattach – See Pad Instructions	_____	_____
Stitching Deterioration	Re-stitch	_____	_____

BEDS – (Black Mat): Beds require periodic re-stitching maintenance every 2 to 3 years. Normal bed life is 5 to 8 years with two re-stitchings. **Make certain the trampoline is visually inspected by a responsible adult, checking the stitching carefully at each “V-ring” before every use. See page 5 for further information on this critical subject.**

Check for:	Necessary Action	Safe	Unsafe
Bent or missing V-rings	Replace V-rings	_____	_____
Faded & breaking top thread	Regular re-sew	_____	_____
Brittle & tearing V-ring tabs	Complete re-sew	_____	_____
Cuts, tears, or holes on bed	Patch* (Holes greater than 1” cannot be repaired)	_____	_____
Missing Warning Labels	Phone manufacturer for replacement	_____	_____

SPRINGS: The life of a set of springs is 2 to 5 years depending on weight of jumpers, frequency of use, and care.

Check for:	Necessary Action	Safe	Unsafe
Over-stretched springs	Replace	_____	_____
Missing springs	Replace	_____	_____
Weak (soft) springs	Replace	_____	_____

FRAME: The life of your JumpCourt Trampoline frame should last 5 to 10 years, depending upon the weather in the area where you live.

Check for:	Necessary Action	Safe	Unsafe
Rust	Clean & paint	_____	_____
Structural failure	Replace	_____	_____
Bent frame	Repair or replace part	_____	_____
Sharp protrusions	Repair	_____	_____
Missing frame warning labels	Phone manufacturer for replacement	_____	_____

SAFETY RULES – Review this manual with all jumpers. Maintain all warning labels and signs. If labels or signs become lost or unreadable write or telephone the manufacturer for free replacements.



POINTS OF SAFETY– WARNINGS



It is essential that trampoline users follow a carefully planned safety program so that the trampoline can be fully enjoyed. Most accidents can be classified into the following headings:

LANDING ON SPRINGS OR FRAME

The risk of falling on, landing between the springs, or hitting the frame, can be reduced through: proper mounting and dismounting of the trampoline; emphasizing jumping at the center of the bed without traveling toward the sides; and by the installing quality frame pads. Simple frame pads or spring covers on their own, do not give adequate protection. Installing a **JumpCourt® Safety Enclosure**, or using spotters will greatly reduce the risks of injury mentioned above.

BOUNCING OFF THE TRAMPOLINE

This problem can be controlled, if not completely eliminated, through proper instruction and mastering of “STOP BOUNCE,” maintaining a position in center of bed, strictly forbidding any “FLYING DISMOUNT,” installing a **JumpCourt Safety Enclosure**, or using spotters. Keep other objects away from the trampoline. It is a dangerous practice to jump from the trampoline to the floor or ground. Do not jump from the trampoline into a swimming pool, a swing, or any other object. Do not install trampoline on concrete, asphalt or hard compacted surfaces.

LANDING INCORRECTLY ON THE BED

Landing incorrectly on the bed creates great risk of a serious injury with most of these resulting from attempting somersaults. **IT IS STRONGLY RECOMMENDED THAT SOMERSAULT PROCEDURES NOT BE PRACTICED.** Serious injury or death may occur.



READ THE FOLLOWING PRECAUTIONS



1. Do NOT attempt somersaults. Landing on your head or neck can cause serious injury, paralysis, or death, even when landing in the middle of the bed.
2. Do NOT allow more than one person on the trampoline at a time. Use by more than one person at the same time can result in serious injuries.
3. Use trampoline only with mature, knowledgeable supervision.
4. Trampolines over 20 in. (51 cm) tall (including this trampoline) are NOT recommended for use by children under 6 years of age.
5. Inspect the trampoline before each use. Make sure the frame padding is correctly and securely positioned. Replace any worn, defective or missing parts.
6. Climb on and off the trampoline. It is dangerous to jump onto the trampoline when mounting. Do NOT use the trampoline as a springboard to other objects.
7. Stop your bounce by flexing your knees as your feet come in contact with the trampoline bed. Learn this skill before attempting others.
8. Learn fundamental bounces and body positions thoroughly before trying more advanced skills. A variety of trampoline activities can be carried out by performing the basic fundamentals in various series and combinations, performing one fundamental after another, with or without feet bounces between them.
9. Avoid bouncing too high. Stay low until you can control your bounce and repeatedly land in the center of the trampoline. Control is more important than height.
10. Focus your eyes on the perimeter of the trampoline. This will help control your bounce.
11. Avoid bouncing when tired. Keep turns short.
12. Properly secure the trampoline when not in use. Protect it against unauthorized use. If a trampoline ladder is used, the supervisor should remove it from the trampoline when leaving the area to prevent unsupervised access by children under 6 years of age.
13. Keep objects away which could interfere with the performer. Maintain a clear area around the trampoline.
14. Do not use the trampoline while under the influence of alcohol or drugs.
15. For additional information concerning the trampoline, contact the manufacturer.
16. For information concerning skill training, contact a certified trampoline instructor.
17. Bounce only when the surface of the bed is dry. Wind or air movement should be calm to gentle. The trampoline must not be used in gusty or severe winds.
18. Read all instructions before using the trampoline. Warning and instructions for the care, maintenance and use of this trampoline are included to promote safe, enjoyable use of this equipment.

BASIC SKILLS

BOUNCING

The most important thing about bouncing is that it should be done with control in the center of the bed. The basic bounce should always begin low. High, reckless bouncing should never be allowed.

The Stop Bounce

This technique allows the jumper to gain control by stopping quickly. It is done by keeping the feet in contact with the bed, and absorbing *the rebound of the trampoline with the knees and waist*. This skill should be learned right away and should be employed whenever you feel out of balance, or land away from the center area.

To learn the stop bounce:

- (1) Stand in center of the bed with your feet about hip-width apart.
- (2) Attempt about three easy bounces, keep them *low and controlled*.
- (3) Focus your eyes towards the perimeter of the trampoline while bouncing in order to keep your balance.
- (4) Stop the bounce by bending at your knees and hips on contact with the bed.

ARM ACTION

Arms are very important for proper control and lift. Whenever you go up, your arms go up. They go up to a set position about shoulder height and shoulder width. They should remain in this balanced position until you start down. Then they circle down and slightly behind the hips, ready to lift again as you bounce up.

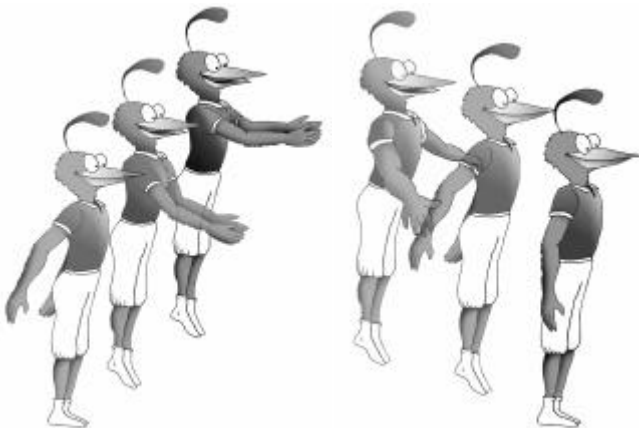

BOUNCE VARIATIONS

The following figures show three variations, which should be assumed at the top of the bounce, before resuming the normal landing position on the feet.



Tuck



Pike



Straddle Pike

Practice these simple variations and concentrate on perfect form. Make sure that the toes are pointed and fingers are straight. Also make sure that you are taking off and landing in the same spot on the center of the bed.

These simple variations to the basic bounce can be a lot of fun, and are very important for gaining experience in coordinated movement.

BASIC LANDING POSITIONS

Positions for all drops (seat, hands and knees, front, and back) should first be performed on the ground, then in a stationary position on the trampoline bed.

Once the position is correctly executed, the drop can be performed after “priming” the trampoline bed. Priming is done by bending the knees and pushing down repeatedly on the trampoline bed, thereby setting the bed in motion. The feet stay in contact with the bed during the entire priming motion.

The Seat Drop

- (1) From the standing position, prime the bed several times.
- (2) Pick up your feet at the top of the last bounce, and sit down. You should land so that your body is in a sitting position with your legs straight out in front of you and your toes pointed. Hands should be on the bed next to your hips. Fingers should be together and pointed toward the toes.
- (3) Push on the bed with your hands to rebound up to your

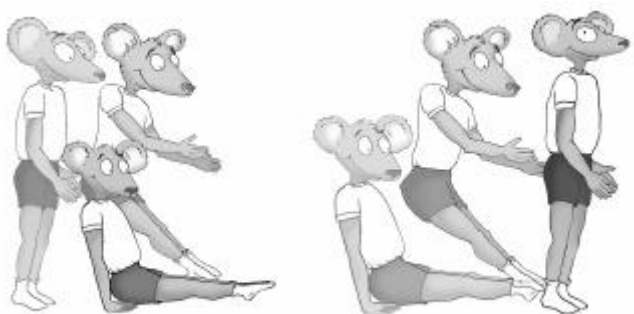

The Hands and Knees Drop

To do this drop properly, there should be just as much weight on the hands as on the knees. The back should be about parallel to the bed. The knees and hands should land simultaneously, with the middle of the body landing in the center of the trampoline. The hands should be directly under the shoulders. The knees should be directly under the hips. The toes should be pointed.

- (1) Get down on your hands and knees on the bed. Make sure you have weight on both your hands and your knees. Don't sit on your heels.
- (2) Remain in this position and try to bounce. Don't rock back and forth between the hands and knees, but develop an even landing on all four points.
- (3) From the standing position, prime the bed several times. Lift upward with the hips, reach forward with the hands, and land on all fours. Look slightly in front of your hands on landing. Push to rebound to your

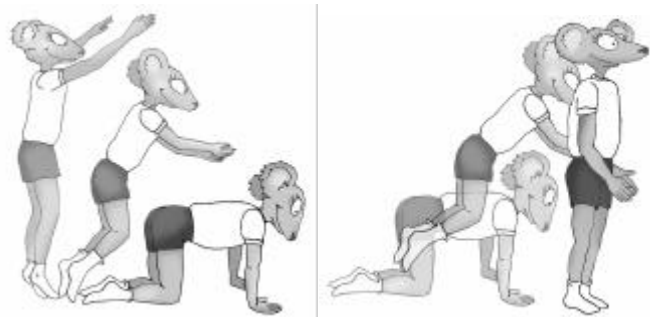

feet.

The Front Drop

Contact with the trampoline bed should simultaneously take place with your hands, elbows, chest, stomach, and hips. Knees should be bent.

Hands should be placed close together with palms in contact with the bed forming a triangle. Eyes should be focus on triangle or slightly in front of your fingers.

STEP 1:

- (1) Start from the hands and knees drop position.
- (2) As you rebound from the hands and knees, stretch so that you land on your stomach. From this position, rebound to your hands and knees.

STEP 2:

- (1) Start from a standing position with knees bent so that your upper body is low and close to the trampoline bed.
- (2) Prime the bed several times.
- (3) Lift hips gently upward and backward.
- (4) Land in contact with the bed as described in Step 1.
- (5) Push with the hands to return to the feet.

STEP 3: (See next page)

- (1) Start from a straight standing position.
- (2) Prime the bed several times.

Perform skill as in Step 2.

***Important:** You must come down level. If the landing is made first on the chest and arms, they will rebound before the knees hit which will result in a straining action on the back. If this type of landing is made with a traveling, diving approach there is a good chance that the elbows may become skinned. If the landing is made so that the knees and hips hit first, then they will rebound and the shoulders and face will land heavy.*

1-3



4-6



Series of drops

Once you have mastered the individual bounce variations and drops, perform them in sequence. For example: Seat Drop – Hands and Knees Drop – Front Drop, or Seat Drop – Front Drop – Hands and Knees Drop – Seat Drop.

BEGINNING TWISTING

The following figures will show you a few of the many possible twisting variations of the basic landing positions.

Seat Drop – Half Twist – Seat Drop (AKA: Swivel Hips)

STEP 1:

- (1) Perform a seat drop.
- (2) Push down on the bed with the hands and come to a stand with the arms stretched overhead.

STEP 2:

- (1) Perform the movement in Step 1. As you rebound up to your feet, move one shoulder in the direction you want to twist.
- (2) Finish standing with arms stretched overhead, facing the opposite direction (180 degree twist completed).

STEP 3:

- (1) Perform as in Step 2. Just before contacting feet with the trampoline bed, lift legs to land in a sitting position (180 degree twist completed).

Front Drop – Half Twist – Front Drop



(AKA: Turntable)

STEP 1:

- (1) Begin in a hands and knees position, with hands forming a triangle, like in a front drop.
- (2) Prime the bed in this position.
- (3) Push backward with hands and extend body to land in the Front Drop position.
- (4) Repeat several times in succession: Hands and Knees Drop – Front Drop – Hands and Knees Drop – etc.

STEP 2:

- (1) Perform the movement as in Step 1. However, do it at twice the speed so as to bring the knees inward, under the hips and out again without touching the knees on the bed.

STEP 3:

- (1) Perform the movement as in Step 2. Push sideways on the trampoline bed so that the body rotates like the hands of a clock.

STEP 4:

- (1) From a standing position, prime the bed, then perform a front drop. Push sideways, as in Step 3, and complete a 180 degree turn, finishing in a front drop facing the opposite position.

Seat Drop – Full Twist – Seat Drop

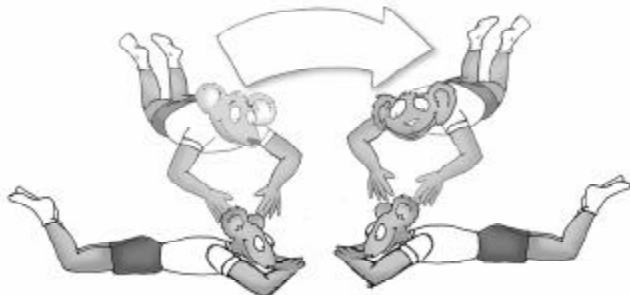

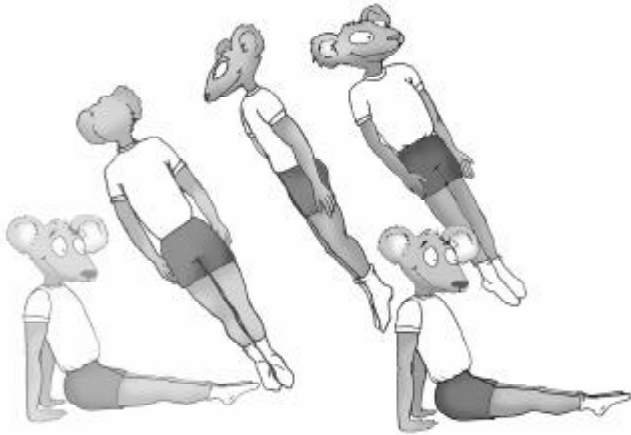

ADDITIONAL TWISTING

You can have hours and hours of fun and challenging bouncing by combining twist with each of the basic landing positions (Drops). You can twist:

After the landing position.

Example: Seat drop – 1/2 twist – feet

You can add more twists. Always remember to practice and perfect the smaller twists before moving on to larger twists.

You can also perform a series of twists.

Example: Swivel Hips Perform several in a row, all twisting in one direction, or alternating directions. Turntable – same as swivel hips.

If you find that you love the trampoline, and have mastered the moves discussed in these instructions, you are encouraged to seek additional training from a CERTIFIED TRAMPOLINE INSTRUCTOR.

JumpSport®

**PLEASE MAIL THE PURCHASE REGISTRATION CARD
WITHIN 10 DAYS FROM DATE OF PURCHASE**

JumpSport®

Limited Warranty

What is covered by this warranty? This warranty covers any defects in materials or workmanship on all of the components of the JumpSport® Trampoline, and is extended exclusively to the original retail purchaser from the date of purchase.

How long does this coverage last? Warranty coverage for each component is as follows:

- Steel frame – is warranted ten years (prorated):
one hundred percent (100%) for the first through fifth year, fifty percent (50%) for the sixth year, forty percent (40%) for the seventh year, thirty percent (30%) for the eighth year, twenty percent (20%) for the ninth year, and ten percent (10%) during the tenth year.
- Stitching on mat (bed) – Two years
- Mat (bed) fabric – Five years
- Frame pads – Six months
- Springs – Five years

What will JumpSport do? If you return the defective part freight prepaid as instructed below, JumpSport will either repair or replace such part, at JumpSport's discretion, and return it to you freight prepaid.

What is not covered by this warranty? This warranty does not cover expenses of on-site labor, travel, assembly or disassembly or other charges associated with the repair or replacement of covered components. This warranty also does *not* cover any problem that is caused by abuse, misuse, ordinary wear, tear, and weathering, acts of God (such as wind and lightning), failure to follow directions, improper installation, or improper maintenance. Rust is a natural occurrence with any outdoor steel product, and is likewise not covered by this warranty to the extent that it does not affect the structural integrity of the part.

JUMPSPORT IS NOT RESPONSIBLE OR LIABLE FOR INDIRECT, SPECIAL OR CONSEQUENTIAL DAMAGES ARISING OUT OF OR IN CONNECTION WITH THE USE OR PERFORMANCE OF THE PRODUCT OR OTHER DAMAGES WITH RESPECT TO ANY LOSS, INCLUDING BUT NOT LIMITED TO ECONOMIC LOSS, LOSS OF PROPERTY, LOSS OF REVENUE OR PROFITS, LOSS OF ENJOYMENT OR USE, COST OF REMOVAL, INSTALLATION OR OTHER CONSEQUENTIAL DAMAGES. SOME STATES DO NOT ALLOW THE EXCLUSION OR LIMITATION OF INCIDENTAL OR CONSEQUENTIAL DAMAGES. ACCORDINGLY, THE ABOVE LIMITATION MAY NOT APPLY TO YOU.

THE WARRANTY EXTENDED HEREUNDER IS IN LIEU OF ALL OTHER WARRANTIES AND ANY IMPLIED WARRANTY OF MERCHANTABILITY OR FITNESS FOR A PARTICULAR PURPOSE IS LIMITED IN ITS SCOPE AND DURATION TO THE TERMS SET FORTH HEREIN. SOME STATES DO NOT ALLOW LIMITATIONS ON HOW LONG AN IMPLIED WARRANTY LASTS. ACCORDINGLY, THE ABOVE LIMITATION MAY NOT APPLY TO YOU.

How to get a defective part replaced: 1) Call the JumpSport Customer Service Department at 1-408-213-2551 to obtain a Return Authorization Number. All returns must be pre-authorized. 2) Send the part(s) to the designated service center freight prepaid, along with a copy of your original sales receipt and a brief written description of the problem, including how it occurred. 3) After inspecting the returned part(s), JumpSport will make a final determination whether the part is covered by this warranty. A repaired or replacement part will be returned to you. Please allow 3 to 4 weeks for delivery.

This warranty gives you specific legal rights. You may also have other rights which vary from state to state.

JumpSport, Inc. P.O. Box 2446 Saratoga, CA 95070 408-213-2551
<http://www.jumpsport.com>