

Fits AlleyOOP and
JumpSport 10 x 17ft
Trampolines



Truss Basketball Backboard Mount Kit User's Manual

⚠️ WARNING

Read these materials prior to assembling and using the truss and basketball set



DO NOT attempt or allow somersaults. Landing on the head or neck can cause serious injury, paralysis or death, even when landing in the middle of the bed.



DO NOT allow more than one person on the trampoline. DO NOT allow more than one person inside the trampoline enclosure. Use by more than one person at the same time can result in serious injury.

Use trampoline only with mature, knowledgeable supervision.



DO NOT attempt to jump over the barrier.



DO NOT intentionally rebound off the barrier.

DO NOT hang from, kick, cut or climb on the barrier.

⚠️ CALIFORNIA PROP. 65 WARNING
This product contains chemicals known to the State of California to cause cancer, birth defects, or other reproductive harm.

Retain address information for future use.

JumpSport, Inc.
2055 South 7th Street
San Jose, CA 95112 U.S.A.

1-408-213-2551
www.JumpSport.com

Patent info at: patents.JumpSport.com
BBJ-S-21793-00
Instruction Manual P/N: INS-P-21874-00C
Copyright © 2022, by JumpSport, Inc. All rights reserved.

Assembly and Installation Instructions

Thank you for purchasing the Truss Basketball Backboard Mount Kit!

The following pages contain diagrams, pictures, and written instructions for installing your truss basketball mount kit. *Familiarize yourself with the Assembly and Installation Instructions before beginning installation.*

For installation questions, please contact JumpSport’s Customer Service department at: 408-213-2551
6:00am – 5:00pm Monday through Friday, Pacific Time

Tools

Installation of the truss basketball adapter kit requires a 13mm hex wrench which is included in the backboard kit. An 8 foot A-Frame ladder will be useful for some steps (use care and follow procedures for use). Safety glasses and gloves are also recommended for safety. A rubber mallet may also be useful.

Parts List

Your Truss Basketball Backboard Mount kit is shipped with the parts shown below. If any parts are missing, immediately call JumpSport Customer Service at 408-213-2551.

Reference #	Part #	Description	Quantity
1	ADA-P-21795-00	Truss Basketball Backboard Mount Assembly	1
2	BOL-P-21119-00	Eyebolt	2
3	SE-CAP-X-0388	Eyebolt cap cover	2
4	NUT-P-10084A	M8 Nut with nylon insert	2
5	NUT-P-10622A	M8 Acorn nut	2



Reference #1

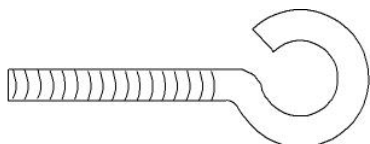

Reference #2

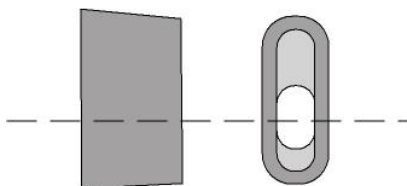

Reference #3

⚠ CAUTION

Pinch point.
Pay careful attention to hand position when connecting tubes.

Assembly and Installation Instructions

- 1) Assemble the basketball set as explained in your basketball set instruction manual, using the Type A assembly instructions. When you get to Step 10 in that manual, instead of installing the basketball set to the top of a safety enclosure pole, install it to the mounting tube in the middle of the Truss Backboard Mount Assembly as shown.

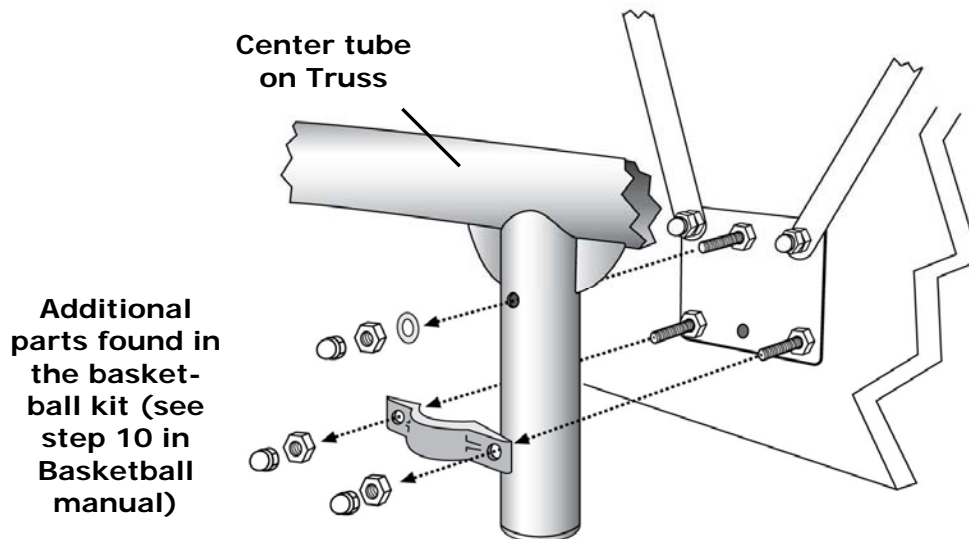

For the steps that follow, you may choose to use an 8 foot A-Frame ladder with the aid of a spotter. Please use care and follow procedures for use. Safety glasses and gloves are also recommended for safety.

- 2) Identify the end of the trampoline best suited to install the backboard. The area should be free from obstructions and have plenty of overhead clearance. If the doorway to your trampoline enclosure is on an end, install the backboard on the opposite end. Remove the top of net from the slot of the ball cap at these two poles, and remove the ball caps. Keep the ball caps in case you want to use them again later.
- 3) Install the Truss Basketball Mount Assembly on to the ends of the enclosure poles. It will likely be easier to align the truss over the top of both poles at the same time. You may need to adjust the position of the poles by moving the tops. It should not be necessary to loosen the bolts connecting the poles to the trampoline frame to accomplish this, but placing the net in a location that will not flex the poles during installation of the truss can be helpful. Align the holes on the enclosure poles with the holes on the truss sockets. A rubber mallet may be helpful, but it is better to adjust the poles so that they do not bind during installation.



Assembly and Installation Instructions

4) Install an Eyebolt (Ref. #2) through an Eyebolt Cap Cover (Ref. #3) then through the truss and enclosure holes, so that the HOOK IS ON THE OUTSIDE OF THE TRAMPOLINE ENCLOSURE. TEMPORARILY hand-tighten a Nut with nylon insert (Ref. #4) to hold the eyebolt in place. Hook the top of the enclosure net assembly (strap and aperture of the net) into the eyebolt hook, and orient the Eyebolt Cap Cover so that the Eyebolt hook is closed and facing up, then tighten the Nut with Nylon Insert with a wrench so that the Eyebolt Cap Cover is fixed against the enclosure pole, and the net is locked securely to the pole., then install Acorn Nut (Ref. #5). Important: Make sure Acorn nut is installed tight enough so that it remains fixed in place, so that the ends of the eyebolt are covered. Repeat at the second pole. Basketball set, Mounting Truss, and Enclosure Net should now be secured to top of safety enclosure pole.

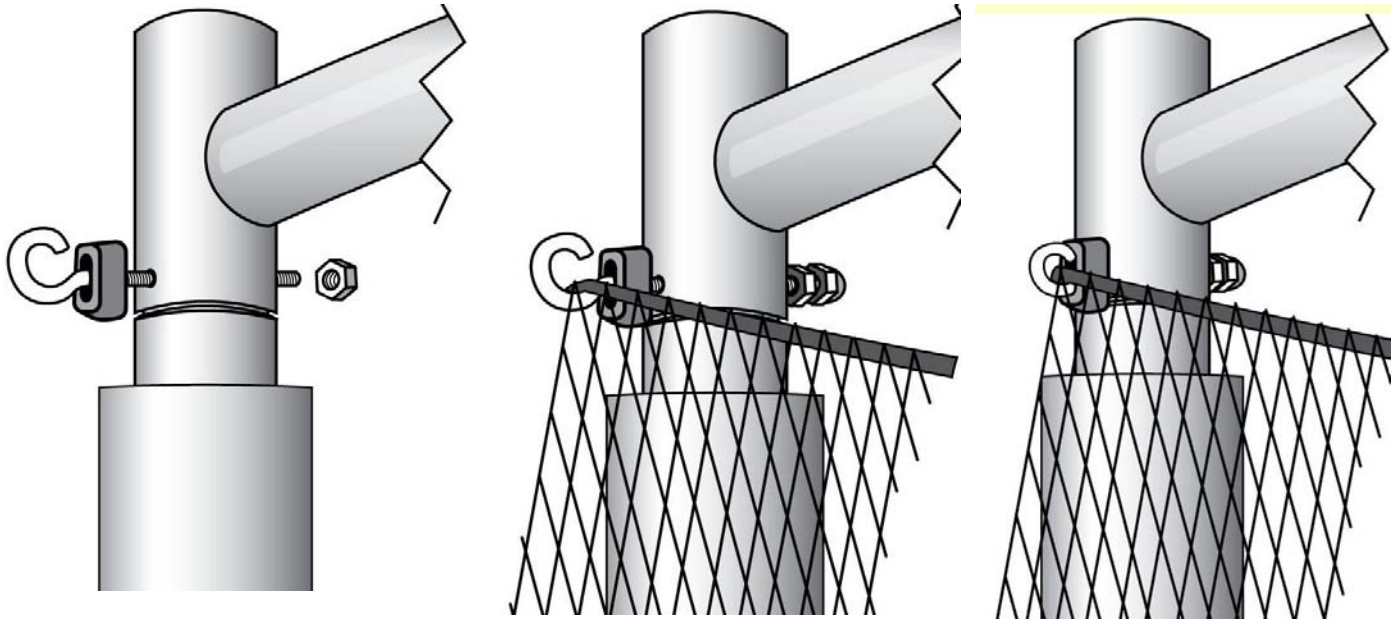

Your basketball adapter kit is now installed!

To remove the basketball adapter kit, follow the Installation Instructions in reverse order.

Important: Please remember, do *not* hang from the basketball set or truss mount.

JumpSport®

Limited 90 Day Warranty

What is covered by this warranty? This warranty covers any defects in materials or workmanship on all of the components of the JumpSport Truss Basketball Backboard Mount Kit, and is extended exclusively to the original retail purchaser.

How long does this coverage last? Warranty coverage for each component begins from the original date of purchase and lasts for 90 days.

What will JumpSport do? If you return the defective part to JumpSport, as instructed below, JumpSport will either repair or replace such part, at JumpSport's discretion, and return it to you.

What is not covered by this warranty? This warranty does not cover expenses of on-site labor, shipping costs, travel, assembly or disassembly, or other charges associated with the repair or replacement of covered components. This warranty also does not cover any problem that is caused by abuse, misuse, commercial or public use, ordinary wear and tear, weathering, acts of God (such as wind and lightning), failure to follow directions, improper installation, improper maintenance, or any silk screened graphics. Rust is a natural occurrence with any outdoor steel product and is likewise not covered by this warranty, to the extent that it does not affect the structural integrity of the part. (This warranty does not cover the trampoline or any related safety enclosure to which the basketball set attaches. See individual trampoline and safety enclosure warranties for specific coverage details for those products.)

JUMPSPORT IS NOT RESPONSIBLE OR LIABLE FOR INDIRECT, SPECIAL, OR CONSEQUENTIAL DAMAGES ARISING OUT OF OR IN CONNECTION WITH THE USE OR PERFORMANCE OF THE PRODUCT OR OTHER DAMAGES WITH RESPECT TO ANY LOSS, INCLUDING BUT NOT LIMITED TO ECONOMIC LOSS, LOSS OF PROPERTY, LOSS OF REVENUE OR PROFITS, LOSS OF ENJOYMENT OR USE, COST OF REMOVAL, INSTALLATION OR OTHER CONSEQUENTIAL DAMAGES. SOME STATES DO NOT ALLOW THE EXCLUSION OR LIMITATION OF INCIDENTAL OR CONSEQUENTIAL DAMAGES. ACCORDINGLY, THE ABOVE LIMITATION MAY NOT APPLY TO YOU.

THE WARRANTY EXTENDED HEREUNDER IS IN LIEU OF ALL OTHER WARRANTIES AND ANY IMPLIED WARRANTY OF MERCHANTABILITY OR FITNESS FOR A PARTICULAR PURPOSE IS LIMITED IN ITS SCOPE AND DURATION TO THE TERMS SET FORTH HEREIN. SOME STATES DO NOT ALLOW LIMITATIONS ON HOW LONG AN IMPLIED WARRANTY LASTS. ACCORDINGLY, THE ABOVE LIMITATION MAY NOT APPLY TO YOU.

How to get a defective part replaced:

- 1) Call the JumpSport Customer Service department at 408-213-2551 to obtain a Return Authorization number. All returns must be pre-authorized.
- 2) Send the part(s) to the designated Service Center, along with a copy of your original sales receipt and a brief written description of the problem, including how it occurred. You must pay freight and insurance to return the part to JumpSport. At JumpSport's sole discretion, we may ask you to send photographs in addition to or in lieu of returning the part.
- 3) After inspecting the returned part(s), JumpSport will make a final determination whether the part is covered by this warranty. We reserve the right to examine photographs or physical evidence concerning parts claimed to be defective prior to making a final determination concerning the claim. A repaired or replacement part will be returned to you. (Shipping charges may apply.) Please allow 3 to 4 weeks for delivery.

This warranty gives you specific legal rights. You may also have other rights which vary from state to state.