

- 1) Familiarize yourself with the leg pieces (leg and leg cap) and the Allen wrench/drill bit. Leg hardware (leg bushing, lock washer, Allen bolt, and leg plug) may already be installed and covered by the leg plug.

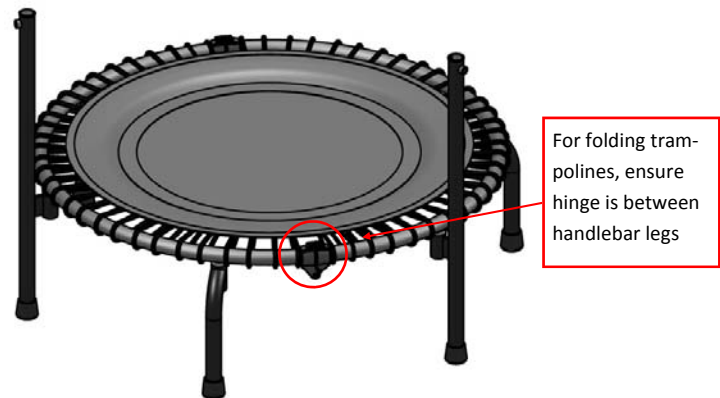

Note: Keep Allen wrench to remove leg mounting bolts and retighten or re-tighten legs, as needed. All bolts should be tight prior to using the rebounder trampoline.

- 2) The handle legs will be installed in place of the normal legs at the two locations shown below for the standard handlebar, or two adjacent legs if using a narrow handlebar. (For safety, if you have a folding trampoline, ensure the hinge is between the two handle legs, as shown below). Turn trampoline upside-down and fit leg sockets over stud on trampoline frame. Notch in leg socket lines up with key on stud. Securely tighten Allen bolts with supplied 6mm Allen wrench. Be sure the Fitness Trampoline logo is centered between the 2 handle legs. When all legs are installed, turn your rebounder over.

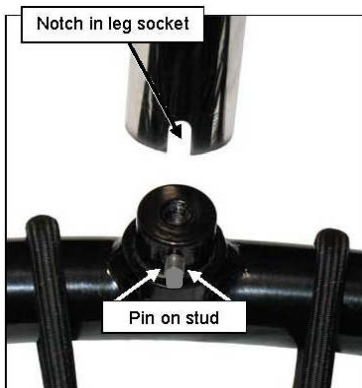

IMPORTANT: Be sure leg caps are installed securely over bottom of legs, as shown above.

Top Handle
39": HAN-A-20841-00
39" Narrow: HAN-A-22045-00
44": HAN-A-20164-03

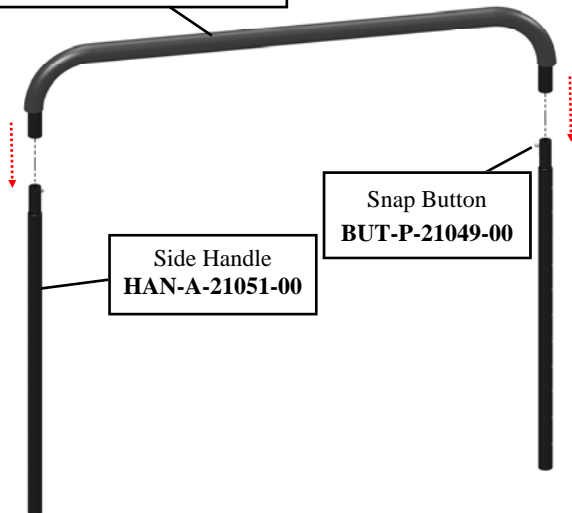

Snap Button
BUT-P-21049-00

Side Handle
HAN-A-21051-00

3) Connect side handles to top handle, and secure both sides with snap buttons to create a "top assembly". **Note:** some top handlebars have two snap button holes on each side, to accommodate curved and straight leg Fitness Trampoline models. Snap side handles into matching/mirroring holes on the top handle, and change if the large thumb screws do not align with the side handle tubes, after performing step 4.

4) Lower top assembly into handle legs. *You may have to rotate entire top assembly 180 degrees for holes to line up.* Adjust height as necessary, before securing with large thumb screws. Revisit Step 3 if the thumb screw holes are not lining up, and the top handle has four snap button holes in total.

Your exercise handlebar is now installed!
To remove the handle, follow the installation instructions in reverse order.

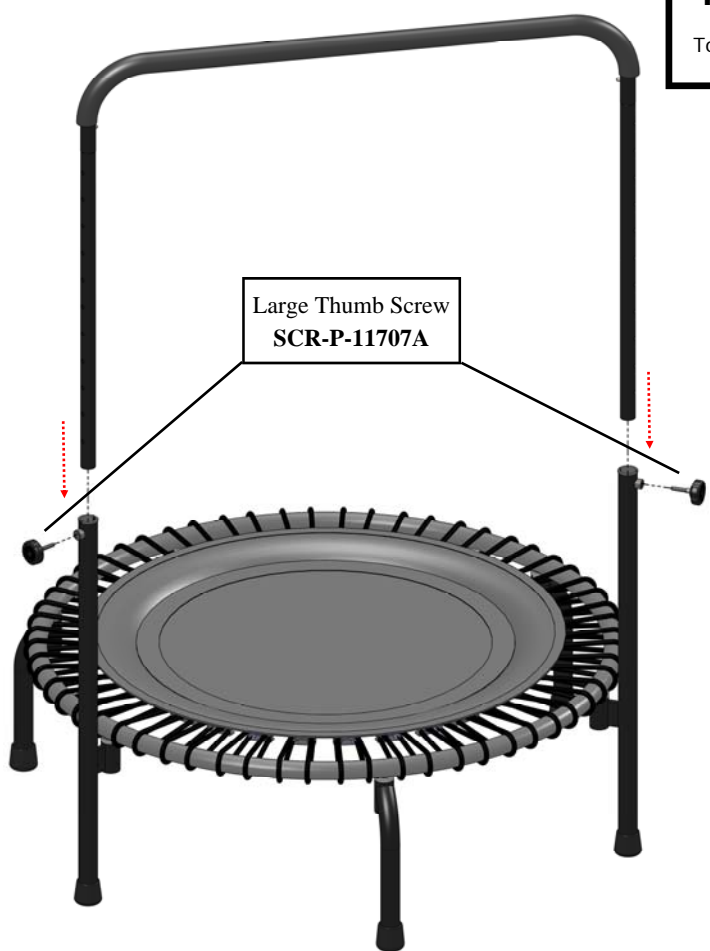

Large Thumb Screw
SCR-P-11707A

CAUTION

Avoid Injury.

- The exercise handle bar is not designed to support your entire weight. It is to aid with balance and provide exercise versatility.
- If you have handle legs attached, do NOT attempt to use the rebounder without first installing the rest of the handlebar pieces.

JumpSport®

Limited Warranty

What is covered by this warranty? This warranty covers any defects in materials or workmanship on all of the components of the JumpSport Exercise Handlebar, and is extended exclusively to the original retail purchaser.

How long does this coverage last? Warranty coverage for each component begins from the original date of purchase and lasts for 1 year (for private home use) or 90 days (for commercial or public use).

How to submit a warranty claim for defective parts:

1) If you notice a defective, missing, or damaged part when first receiving your product, call the JumpSport Customer Service department at 1.888.567.5867 or email Orders@JumpSport.com within 10 days of delivery of merchandise. You may be asked to submit photographs and/or proof of purchase for verification.

2) After using the product, if a qualifying warranty part replacement is needed, customers are required to complete the Warranty Request Form online. Once submitted and reviewed, JumpSport will either repair or replace such parts at JumpSport's discretion. To determine eligibility for warranty replacement, you may be required to either submit photos of the part or send the part to one of our designated service centers.

3) JumpSport will make a final determination whether the part is covered by this warranty. We reserve the right to examine photographs or physical evidence concerning parts claimed to be defective prior to making a final determination concerning the claim. A repaired or replacement part will be returned to you. (Shipping charges may apply.) Please allow 3 to 4 weeks for delivery.

What is not covered by this warranty? This warranty covers new products purchased as a complete system; it does not cover replacement parts. This warranty also does not cover expenses of on-site labor, shipping costs, travel, assembly or disassembly, or other charges associated with the repair or replacement of covered components. Further, this warranty does not cover any problem that is caused by abuse, misuse, commercial or public use of 200 Series models, ordinary wear and tear, outdoor use, weathering, acts of God (such as wind and lightning), failure to follow directions, improper installation, improper maintenance, or any silk screened graphics. Rust is a natural occurrence with any steel product and is likewise not covered by this warranty, to the extent that it does not affect the structural integrity of the part.

JUMPSPORT IS NOT RESPONSIBLE OR LIABLE FOR INDIRECT, SPECIAL, OR CONSEQUENTIAL DAMAGES ARISING OUT OF OR IN CONNECTION WITH THE USE OR PERFORMANCE OF THE PRODUCT OR OTHER DAMAGES WITH RESPECT TO ANY LOSS, INCLUDING BUT NOT LIMITED TO ECONOMIC LOSS, LOSS OF PROPERTY, LOSS OF REVENUE OR PROFITS, LOSS OF ENJOYMENT OR USE, COST OF REMOVAL, INSTALLATION OR OTHER CONSEQUENTIAL DAMAGES. SOME STATES DO NOT ALLOW THE EXCLUSION OR LIMITATION OF INCIDENTAL OR CONSEQUENTIAL DAMAGES. ACCORDINGLY, THE ABOVE LIMITATION MAY NOT APPLY TO YOU.

THE WARRANTY EXTENDED HEREUNDER IS IN LIEU OF ALL OTHER WARRANTIES AND ANY IMPLIED WARRANTY OF MERCHANTABILITY OR FITNESS FOR A PARTICULAR PURPOSE IS LIMITED IN ITS SCOPE AND DURATION TO THE TERMS SET FORTH HEREIN. SOME STATES DO NOT ALLOW LIMITATIONS ON HOW LONG AN IMPLIED WARRANTY LASTS. ACCORDINGLY, THE ABOVE LIMITATION MAY NOT APPLY TO YOU.

This warranty gives you specific legal rights. You may also have other rights which vary from state to state.

JumpSport, Inc.

2055 South Seven Street, Suite A

San Jose, CA 95112

1-888-567-5867

<http://www.jumpsportfitness.com>